

DTU Space
National Space Institute

DTU Technical University of Denmark

www.space.dtu.dk

Lectures on gravity field basics and GRACE

by

Rene Forsberg
DTU Space, Denmark
rf@space.dtu.dk

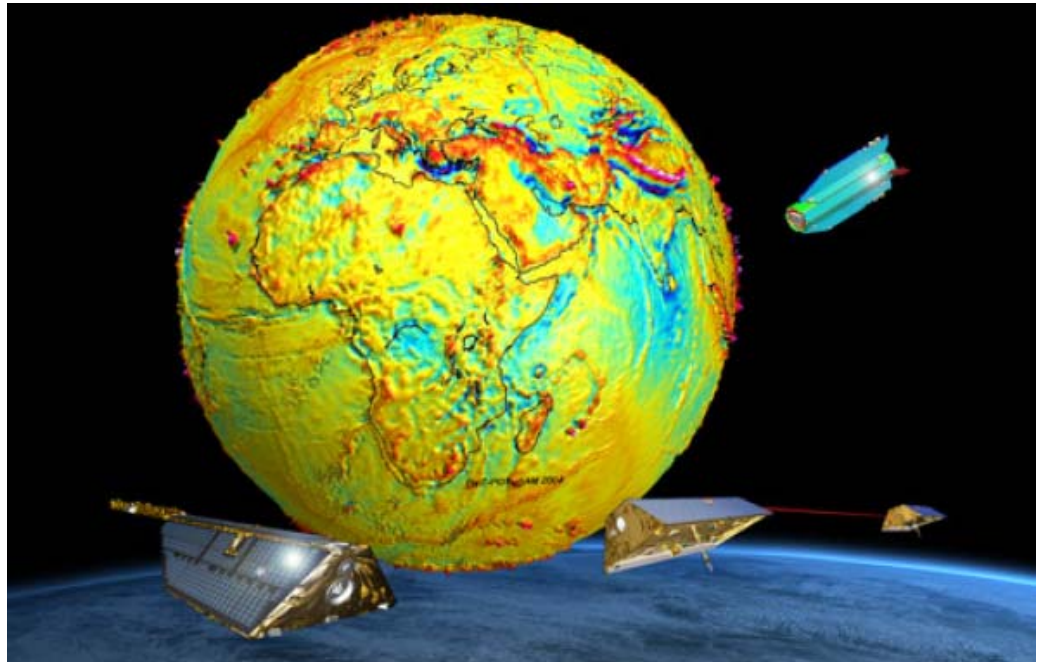

The GRACE mission – gravity change measurements from space

Gravity Recovery and Climate Experiment.

- Launched March 2002, still operating .. some problems
- Joint German-American project (DLR/NASA).
- Mission goal is to measure the Earth's gravity field
 - static and time-varying components.
- Near-polar orbit, inclination of 89°
- Satellite altitude 480-500 km
- Distance between the two satellites ~ 220 km

Data:

Level 1: raw range data

Level 2: spherical harmonics

GFZ or PODAAC (JPL):

RL-4 covers whole period

*RL-5 improved corrections
(tides, atmosphere, oceans)*

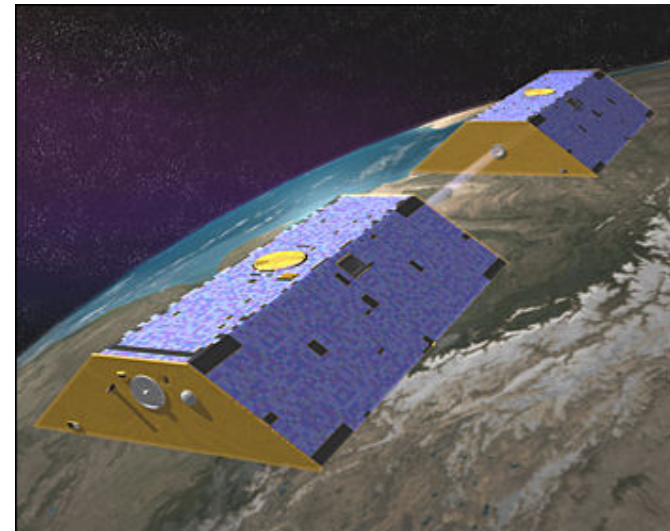
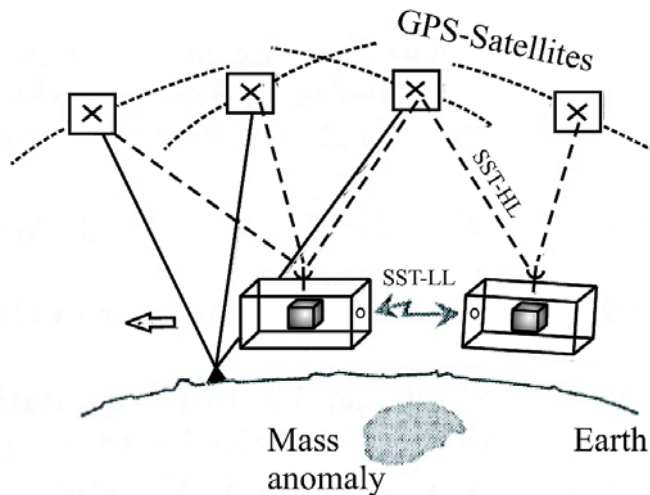

GRACE = Gravity and Climate Explorer

Measurements:

- Intersatellite range and range-rate
 - Precise GPS position of satellite
- 200 km distance, 500 km orbit height
Ku-band, accuracy sub-mm

Level 1-data: Ku-band ranges

.. before tides, atmosphere, ocean corrections ...

Level 2-data: Spherical harmonics

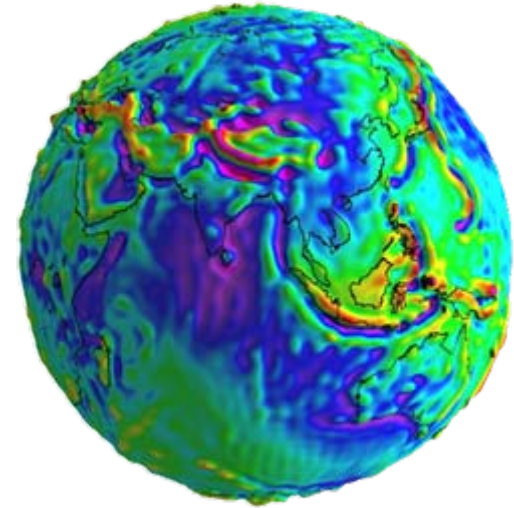

GRACE satellites during construction



GRACE: Ku-band range and range-rate

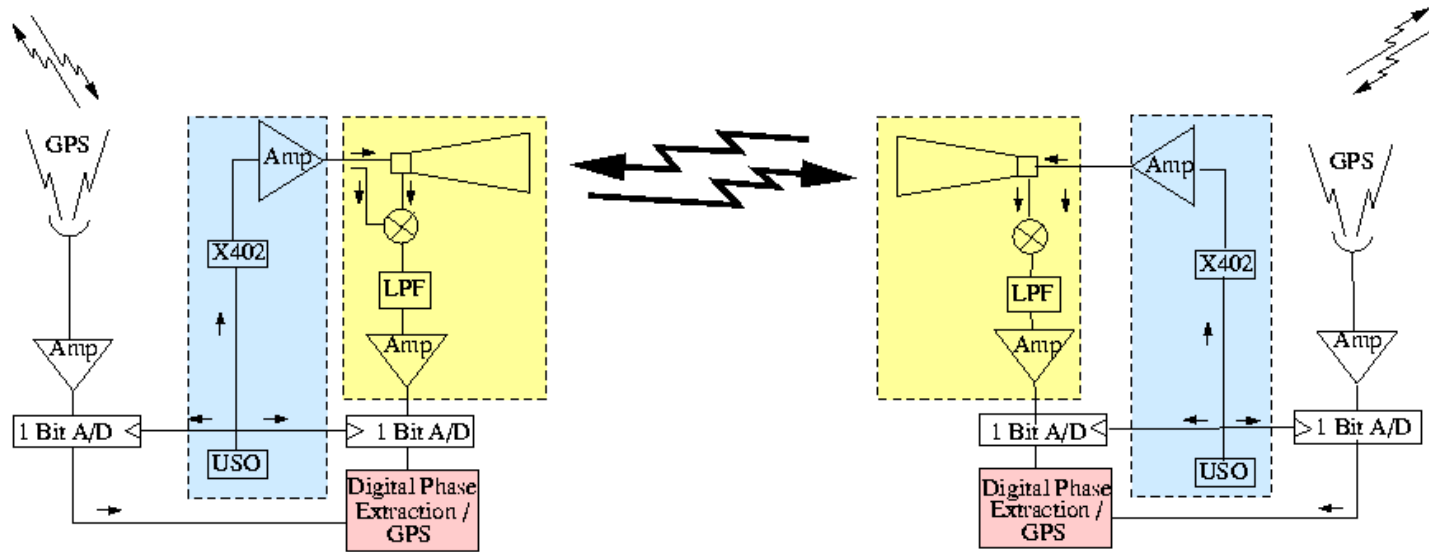

- Single horn antenna for transmission and reception of the dual-band (24 and 32 GHz) k- and ka-band microwave signals,
- Ultra-stable oscillator ([USO](#)) serving as a frequency reference,
- Microwave assembly for up-converting the reference frequency, down-converting the received phase from the other satellite to approximately 2 MHz and for amplifying and mixing the received and the reference carrier phase
- Instrument processing unit (IPU) used for sampling and digital signal processing of the k-band carrier phase signals and the data of the [GPS](#) space receiver, the accelerometer ([ACC](#)) and the star camera assembly ([SCA](#)).

Gravity field basics

- The anomalous gravity field T is the difference between the actual gravity field W and the normal potential U

$$T(\varphi, \lambda, r) = W(\varphi, \lambda, r) - U(\varphi, \lambda, r)$$

- T is a harmonic function outside the masses satisfying

$(\nabla^2 T = 0)$ Laplace (outside the masses)

$(\nabla^2 T = -4\pi\gamma\rho)$ Poisson (inside the masses (ρ is density))

Expanding T in spherical harmonic functions:

$$T = \frac{GM}{R} \sum_{n=2}^{\infty} \sum_{m=0}^n [\bar{C}_{nm} \cos m\lambda + \bar{D}_{nm} \sin m\lambda] \bar{P}_{nm}(\sin \varphi)$$

- \bar{P}_{nm} are associated Legendre functions of degree n and order m
- Geoid heights: multiply coefficients by $1/\gamma$.
- Gravity anomalies: multiply by $(n-1)/R$

Gravity field basics – what is the geoid?

- Bruns formula links geoid N with T ... *geoid* is the undisturbed mean ocean surface (on land: sea level as it would be in a tunnel under continents)

$$N = L_N(T) = \frac{T}{\gamma}$$

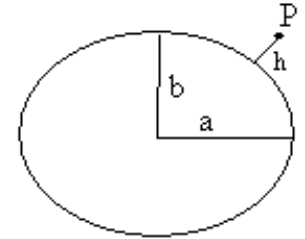

- Gravity anomaly is the difference of actual gravity to normal (ellipsoidal) gravity (free-air anomaly ... with orthometric heights; gravity distance ... with ellipsoid heights)



$$\Delta g = -\frac{\partial T}{\partial r} - 2\frac{T}{r}; \quad \delta g = -\frac{\partial T}{\partial r}$$

- Computing effects of point mass:

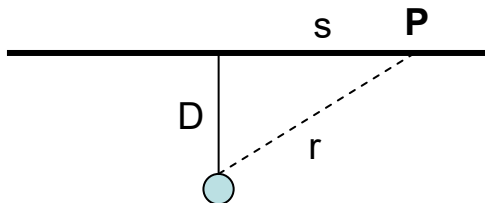

$$N = \frac{1}{\gamma} \frac{GM}{r} = \frac{GM}{\gamma} \frac{1}{\sqrt{D^2 + s^2}}$$

$$\delta g = GM \frac{D}{(D^2 + s^2)^{3/2}}$$

Gravity field basics – global gravity anomaly



Innovision and Office of GEOINT Sciences
Earth Gravitational Model 2008 (EGM08)

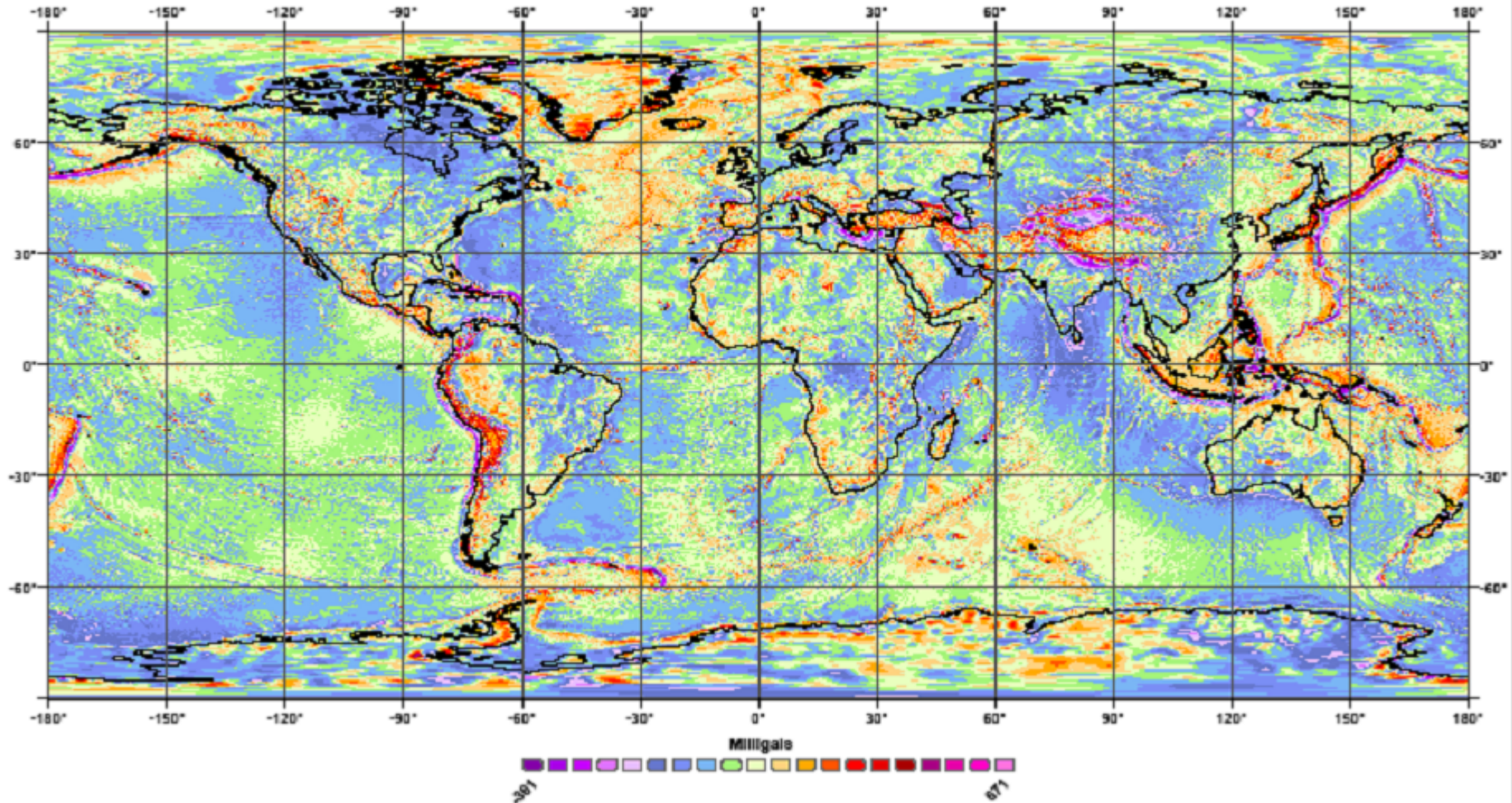

Gravity field basics – global

Geoid is low-pass filtered version of gravity

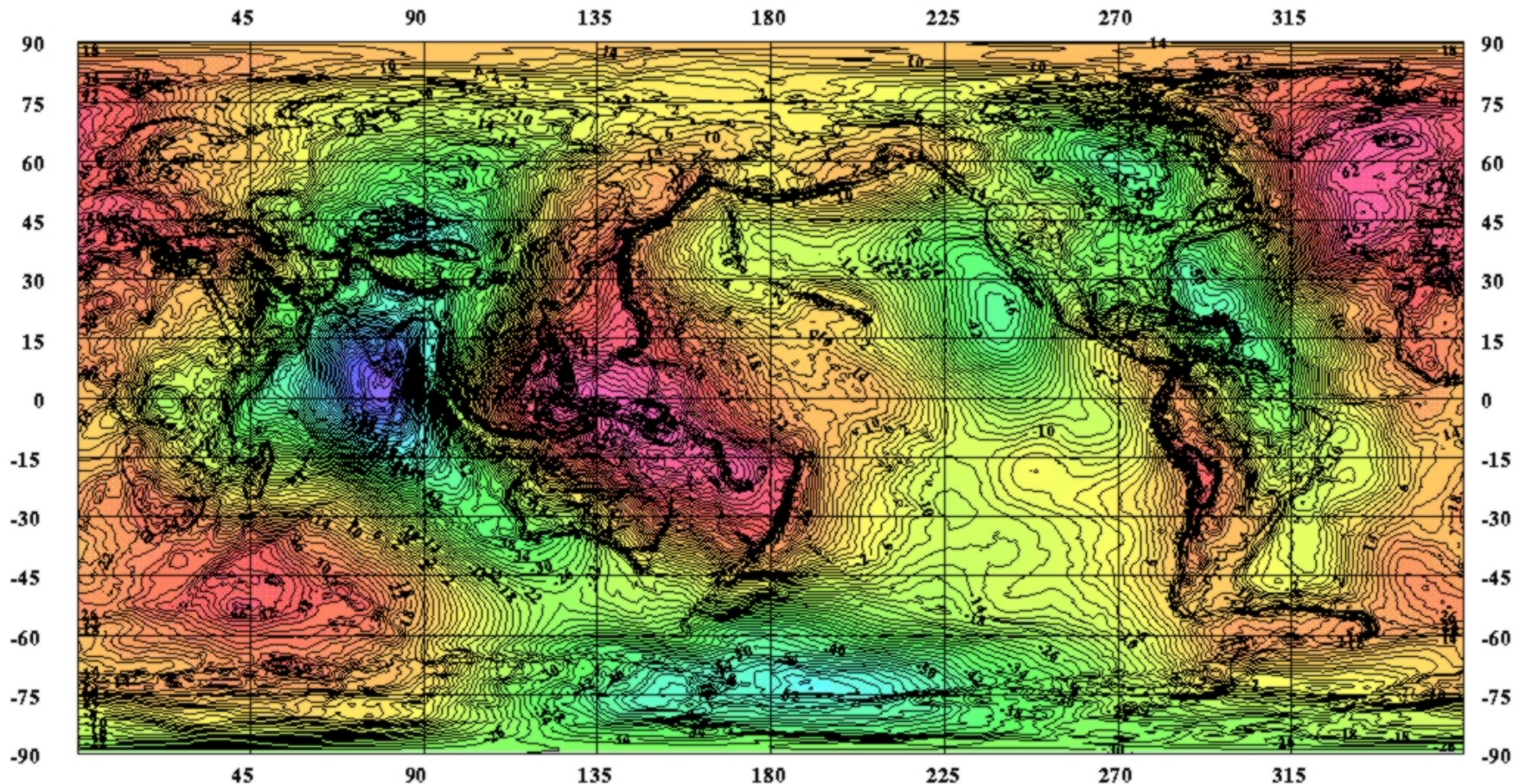

EGM96 15 MINUTE GEOID CI = 2 Meters

-105.0  85.0 Meter

Gravity field basics – orders of magnitude

- On the sphere ... R is earth radius, r computation height, ψ is spherical distance:

$$\delta g_i = Gm_j \frac{R^2 r - R^3 \cos \psi}{[r^2 + R^2 - 2Rr \cos \psi]^{3/2}}$$

- Orders of magnitude – spherical cap of constant surface density κ at height c

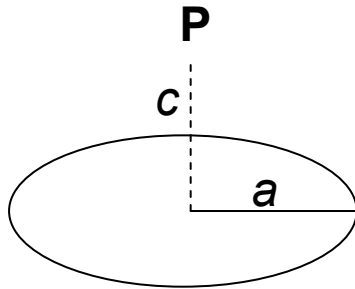

$$N = \frac{2\pi G\kappa}{\gamma} (\sqrt{a^2 + c^2} - c)$$

$$\delta g = 2\pi G\kappa \left(1 - \frac{c}{\sqrt{a^2 + c^2}}\right)$$

Orders of magnitude: 1 m water equivalent, $a = 200$ km, $c = 0$ km:

$$N = 8 \text{ mm}$$

$$\delta g = 0.04 \text{ mGal} = 0.4 \text{ } \mu\text{m/s}^2$$

Spherical harmonics – indispensable for GRACE studies

3d-expression for potential (a : earth radius, GM : gravitational constant x earth mass):

$$T(r, \phi, \lambda) = \frac{GM}{r} \sum_{l=2}^{\infty} \sum_{m=0}^l \left(\frac{r}{a}\right)^{-l} \left[\bar{C}_{lm} \cos m\lambda + \bar{S}_{lm} \sin m\lambda \right] \bar{P}_{lm}(\sin \phi)$$

Gravity and geoid on the sphere $r=a$ (γ : normal gravity):

$$N(\phi, \lambda) = \frac{GM}{a\gamma} \sum_{l=2}^{\infty} \sum_{m=0}^l \left[\bar{C}_{lm} \cos m\lambda + \bar{D}_{lm} \sin m\lambda \right] \bar{P}_{lm}(\sin \phi)$$

$$\delta g(\phi, \lambda) = \frac{GM}{a^2} \sum_{l=2}^{\infty} \sum_{m=0}^l (l+1) \left[\bar{C}_{lm} \cos m\lambda + \bar{D}_{lm} \sin m\lambda \right] \bar{P}_{lm}(\sin \phi)$$

These expressions valid for gravity field, or gravity field *changes* (its all linear...)



Figure 2.2: Illustration of the oscillation of the Legendre functions in the latitudinal direction, also known as the zonal harmonics. Notice that the Legendre polynomials only exist on the interval $\theta \in [0; \pi]$, meaning that these figures should be viewed as a cross-section of the Legendre polynomial, rotated around the north-south axis. The figure is from [Messerschmid and Bertrand \(1999\)](#)

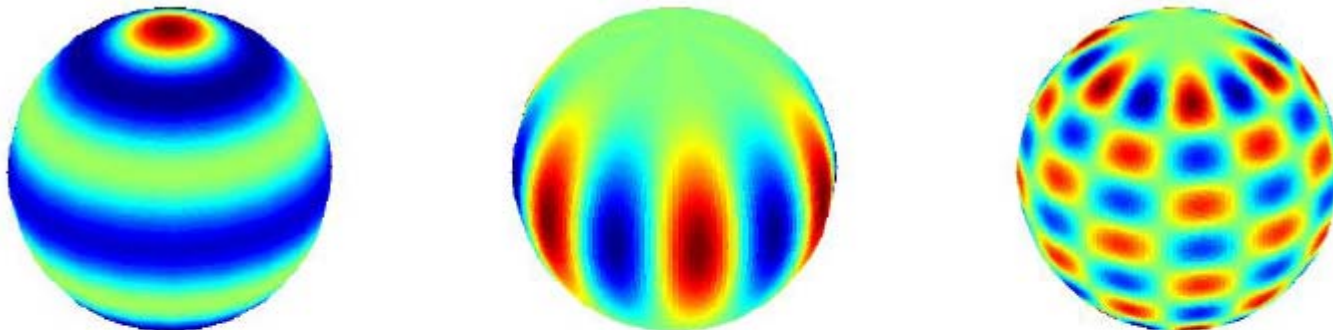

Figure 2.3: Illustration of the 3 kinds of spherical harmonics. Red areas indicative positive values, blue areas are negative. (Left:) zonal harmonics where $m = 0$, above is $P_{6,0}(\cos \theta)$; (middle:) sectorial harmonics where $l = |m|$, above is $P_{6,6}(\cos \theta) \cos(6\phi)$ and (right:) tesseral harmonics are all other cases of l and m , above we have $P_{12,6}(\cos \theta) \cos(6\phi)$.

Link: spherical harmonics to mass changes (surface density σ)

Because mass changes due to hydrology and cryosphere is in a narrow belt relative to GRACE altitude permissible with spherical mass layer assumption

Simple filter relationship spherical harmonic coefficients of $\sigma \leftrightarrow$ geoid
(Wahr 1998 notation – note: he used geoid expansion coefficients, not potential)

$$\Delta N(\theta, \phi) = a \sum_{l=0}^{\infty} \sum_{m=0}^l \tilde{P}_{lm}(\cos \theta) (\Delta C_{lm} \cos(m\phi) + \Delta S_{lm} \sin(m\phi)) \quad (3)$$

Filter relationship between σ coefficients and geoid coefficients – a $(2l+1)$ factor (k-term is loading effect):

$$\Delta \sigma(\theta, \phi) = \frac{a \rho_{\text{ave}}}{3} \sum_{l=0}^{\infty} \sum_{m=0}^l \tilde{P}_{lm}(\cos \theta) \frac{2l+1}{1+k_l} \times (\Delta C_{lm} \cos(m\phi) + \Delta S_{lm} \sin(m\phi)) \quad (14)$$

How now to get mass changes from GRACE?

In principle:

- 1) Get a program for spherical harmonic grid synthesis (e.g. *harmexp* from *GRAVSOFT*)
- 2) Download GRACE Release 5 ("best") coefficients from CSR or GFZ (max degree 60 or 90) – monthly solutions
- 3) Make average geoid coefficients for a period, e.g. 2003-2012.
- 4) Make coefficient differences to average (ΔC_{lm} , ΔS_{lm})
- 5) Evaluate surface mass grids by Wahr (14), put in convenient units (mm water equivalent), and plot => *Time series of mass change*

This won't work ... GRACE data too noisy – need spatial or temporal filtering ..

+ more corrections:

Loading (Love numbers)

– see Wahr Table

C20-coefficients:

- Noisy take from SLR

C10-corrections:

- Swensson, 2008

(disputed, SLR data?)

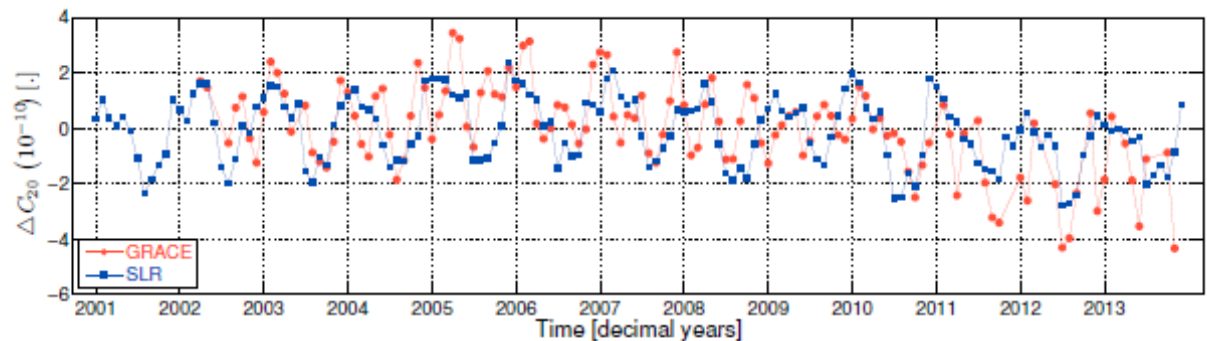

Figure 5.1: Monthly values of the $C_{2,0}$ coefficients from GRACE (red) and SLR (blue). The RMS of the coefficients are $1.39 \cdot 10^{-11}$ for GRACE and $9.58 \cdot 10^{-12}$ for SLR.

Spatial "Wahr" filter: Gaussian averaging – Jekeli (1981)

Space domain

$$\overline{\Delta\sigma}(\theta, \phi) = \frac{2a\rho_{\text{ave}}\pi}{3} \sum_{l,m} \frac{2l+1}{1+k_l} W_l \tilde{P}_{lm}(\cos\theta) \\ \times [\Delta C_{lm} \cos(m\phi) + \Delta S_{lm} \sin(m\phi)]$$

$$W(\alpha) = \frac{b}{2\pi} \frac{\exp[-b(1-\cos\alpha)]}{1-e^{-2b}}$$

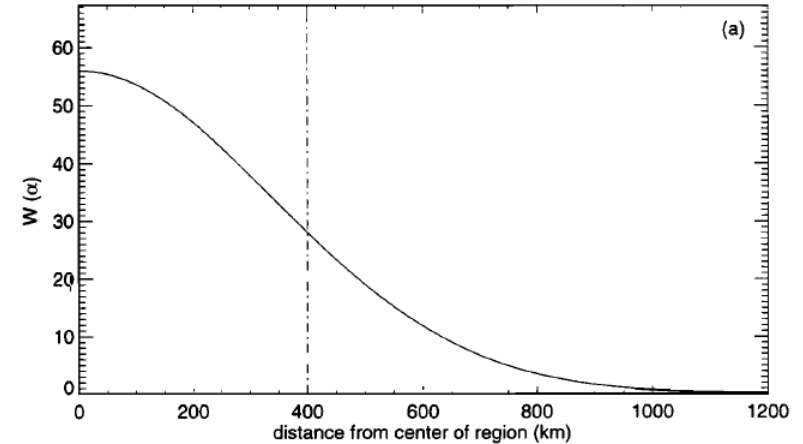

Spherical harmonic domain (recursion)

$$W_l = \int_0^\pi W(\alpha) P_l(\cos\alpha) \sin\alpha d\alpha \quad (31)$$

$$W_0 = \frac{1}{2\pi}$$

$$W_1 = \frac{1}{2\pi} \left[\frac{1+e^{-2b}}{1-e^{-2b}} - \frac{1}{b} \right]$$

$$W_{l+1} = -\frac{2l+1}{b} W_l + W_{l-1}$$

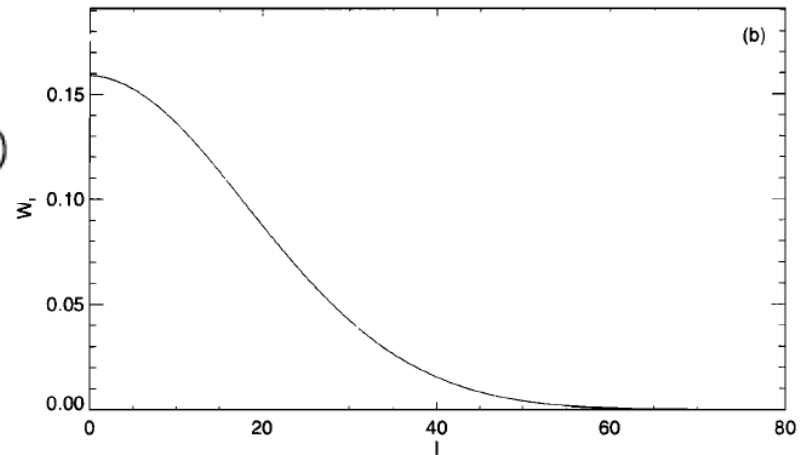

Figure 3. Jekeli's [1981] Gaussian averaging $W(\alpha)$ for an averaging radius of 400 km. (a) W as a function of separation distance (α), where the horizontal line is drawn at 400 km. (b) Spherical harmonic coefficients W_l of this averaging function.

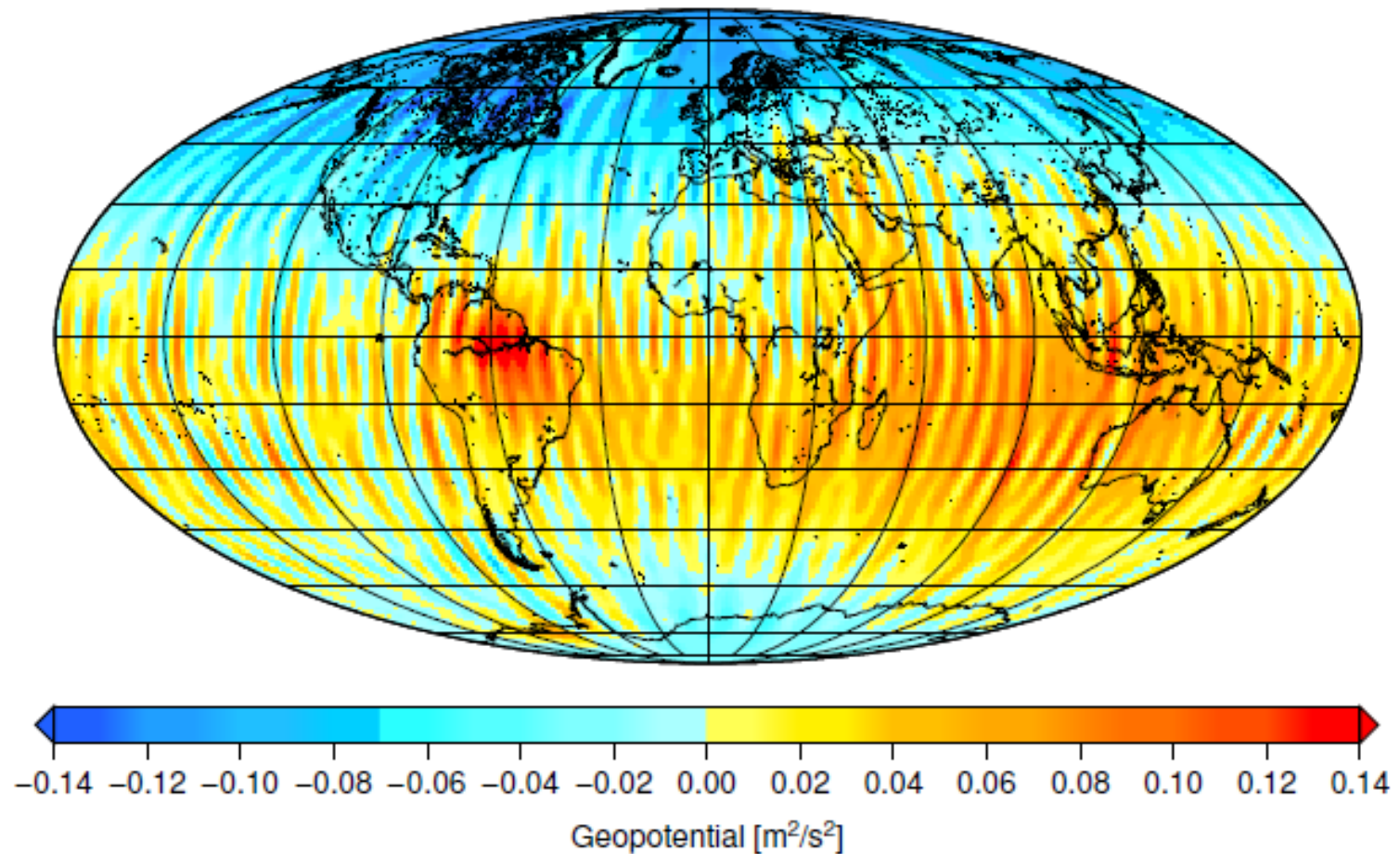

Figure 1.4: The time-variable component of the gravity field measured from GRACE during June 2006. The potential was computed at the surface of the Earth, using a global grid with a resolution of $(1 \times 1)^\circ$, by subtracting the temporal mean of the period from August 2002 until November 2013 from each Stokes coefficient.

(Tim Jensen thesis)

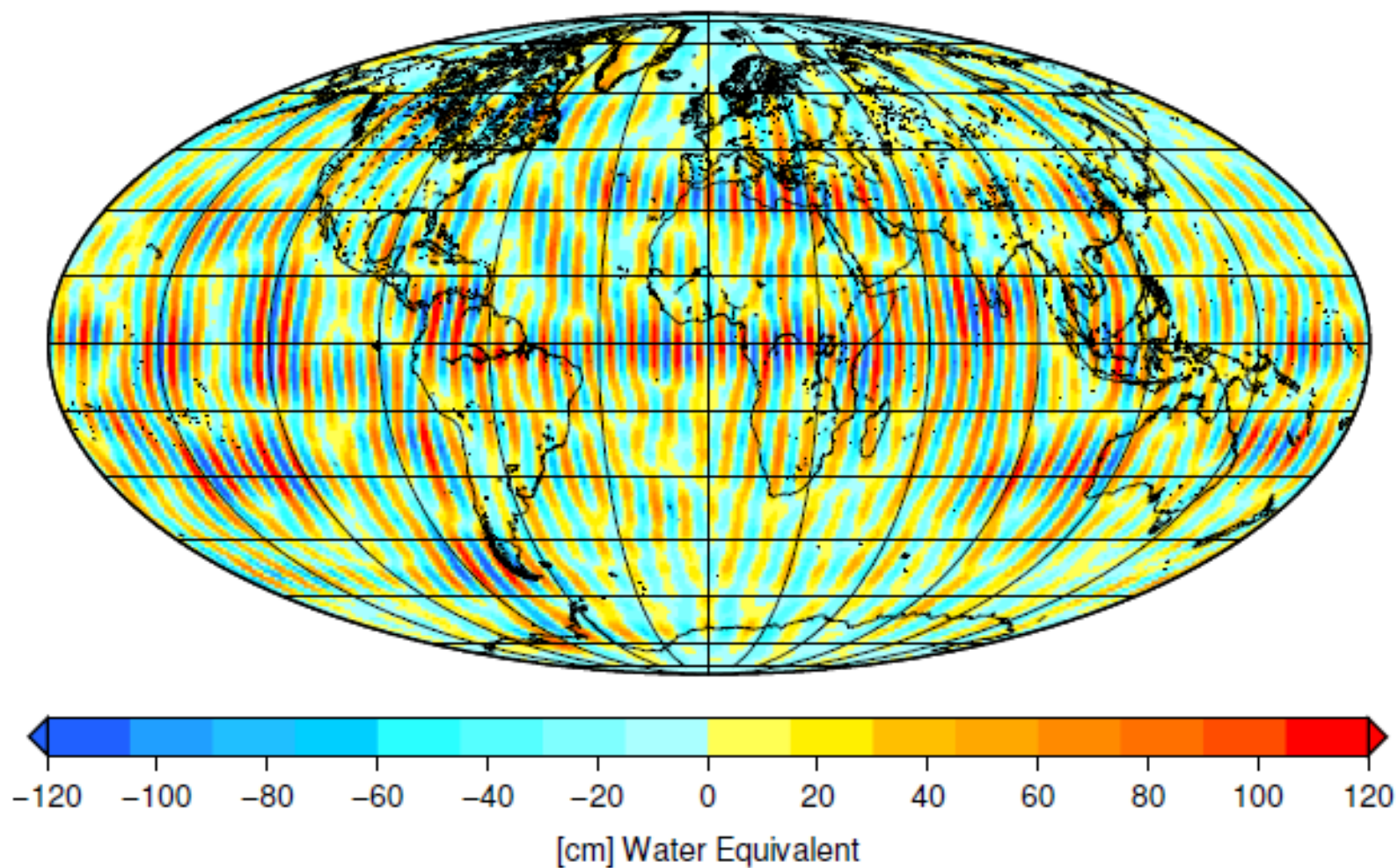

Figure 7.2: The surface mass mass change relative to the mean of the period from April 2002 until November 2013 as measured from GRACE during June 2006. The mass change was computed in a grid of resolution $(1 \times 1)^\circ$.

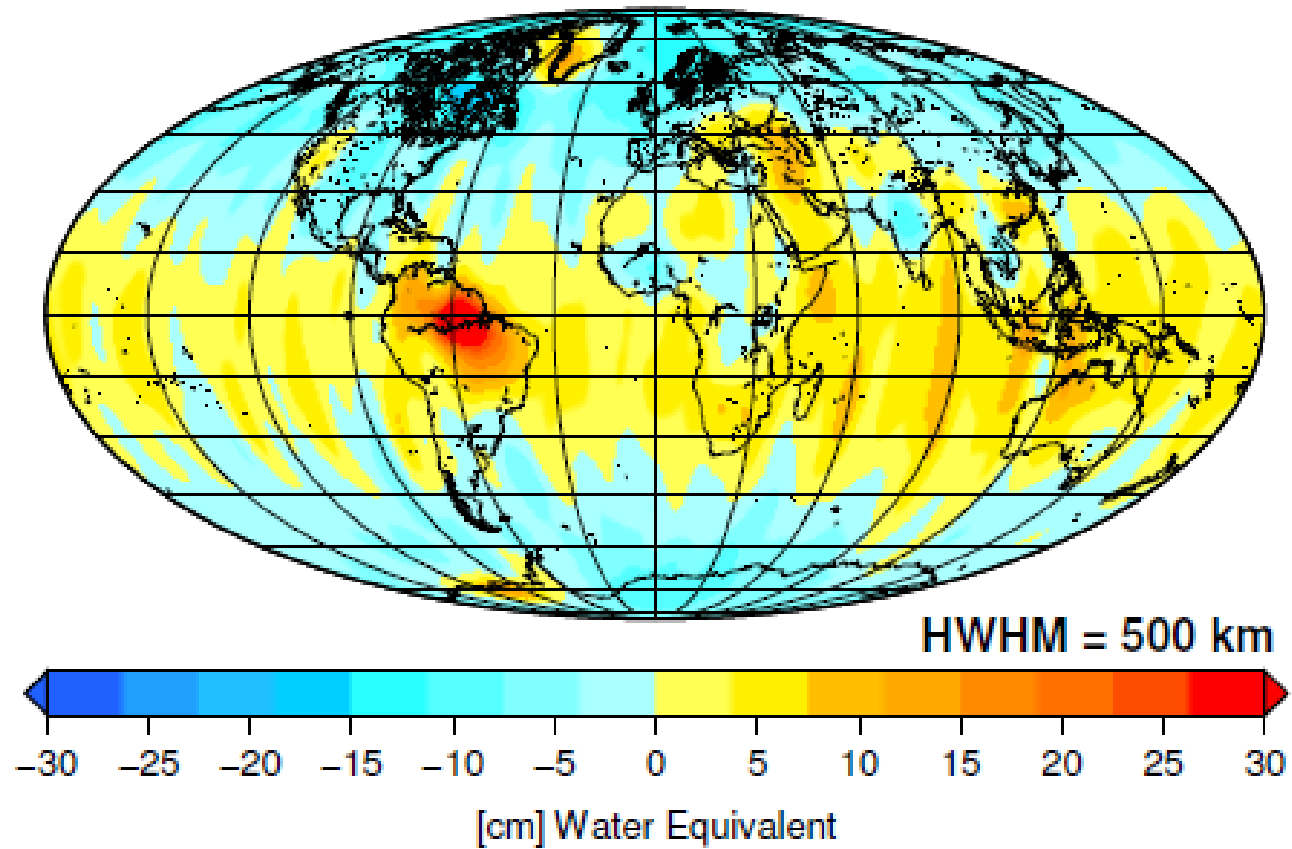

Figure 8.3: The Gaussian smoothing applied to estimated mass balance from June 2006.

But GRACE measures all mass changes ... *results need modelling*

- Oceans and atmosphere: mass changes *modelled* from ECMWF fields and subtracted in provided C_{lm} , S_{lm} coefficients (corrections provided too)
- Tidal effects removed by models (de-aliasing)
- Ocean current mass changes removed by models => GRACE coefficients mainly *land hydrology, GIA and cryosphere effects ...*
- Hydrology and GIA can be corrected by models => *cryosphere mass changes*
- Most controversial correction: *leakage ...*

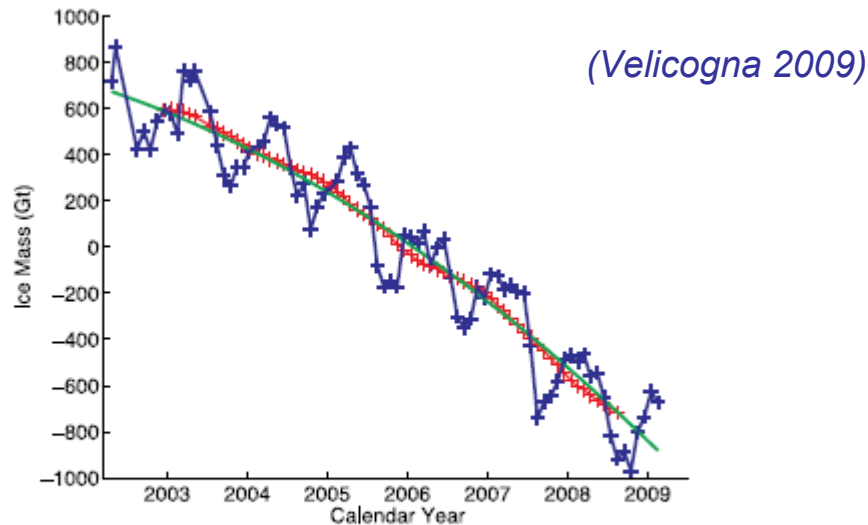

Figure 1. Time series of ice mass changes for the Greenland ice sheet estimated from GRACE monthly mass solutions for the period from April 2002 to February 2009.

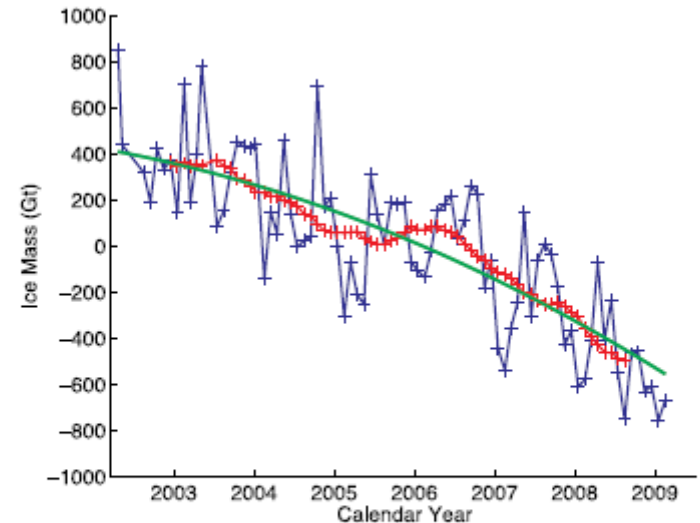

Figure 2. Time series of ice mass changes for the Antarctic ice sheet estimated from GRACE monthly mass solutions for the period from April 2002 to February 2009.

- Leakage corrections try to take into account signal loss from filtering and neighboring mass changes .. very ad-hoc process (Wahr paper)
- Better anisotropic filtering (Kusche) help to reduce "striping" and need for filtering
- Or use methods taking into account know area of changes – **inversion methods**

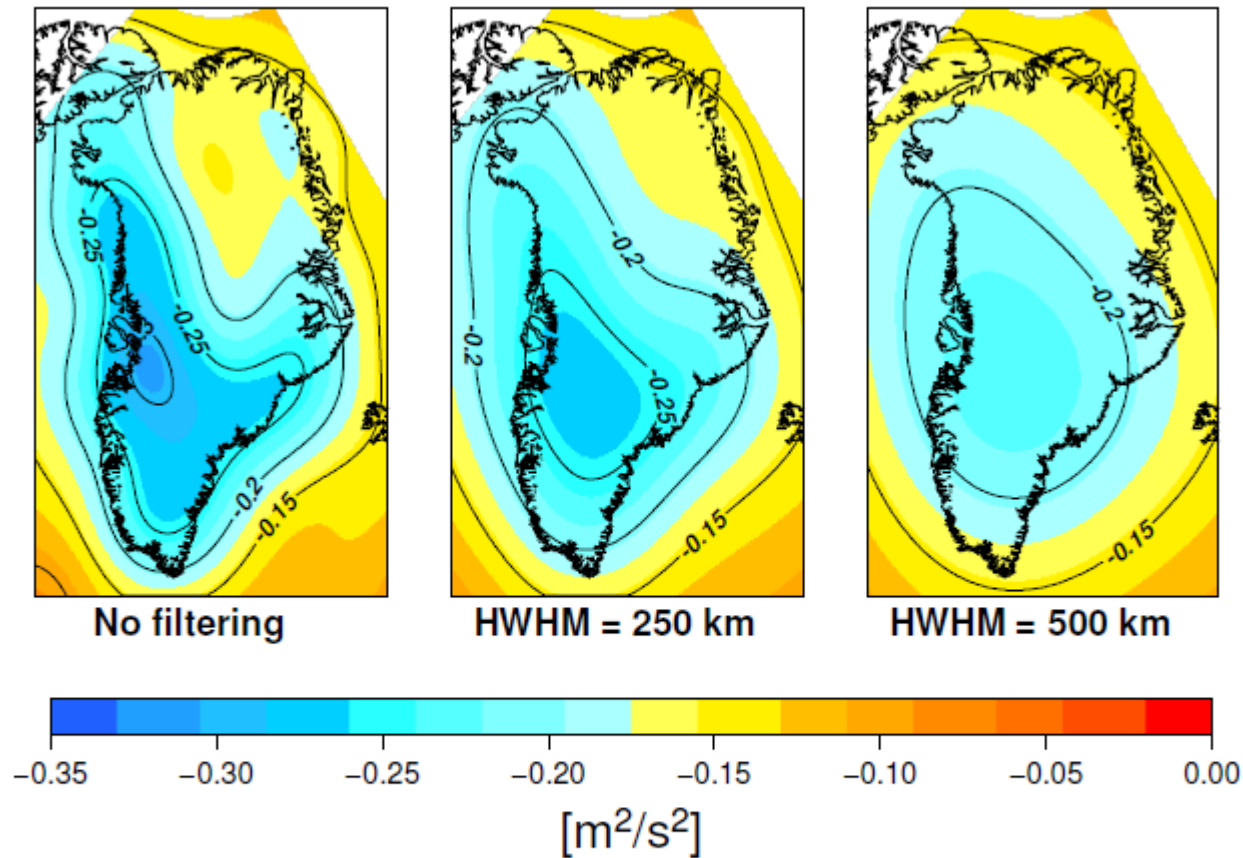
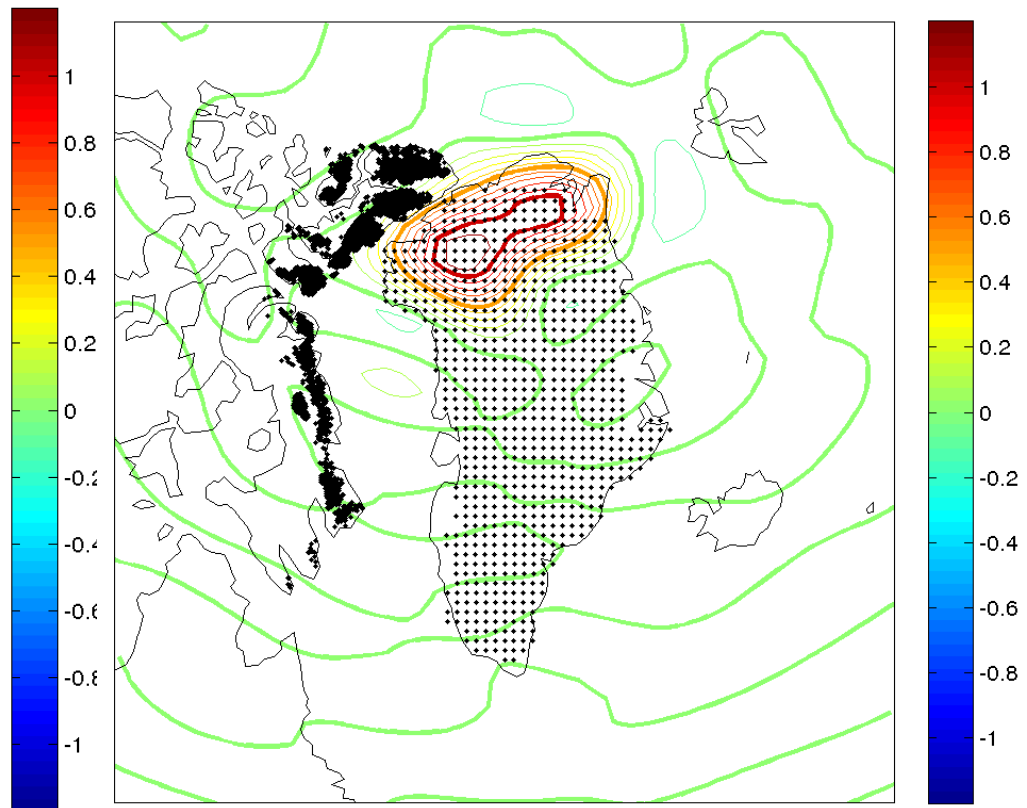
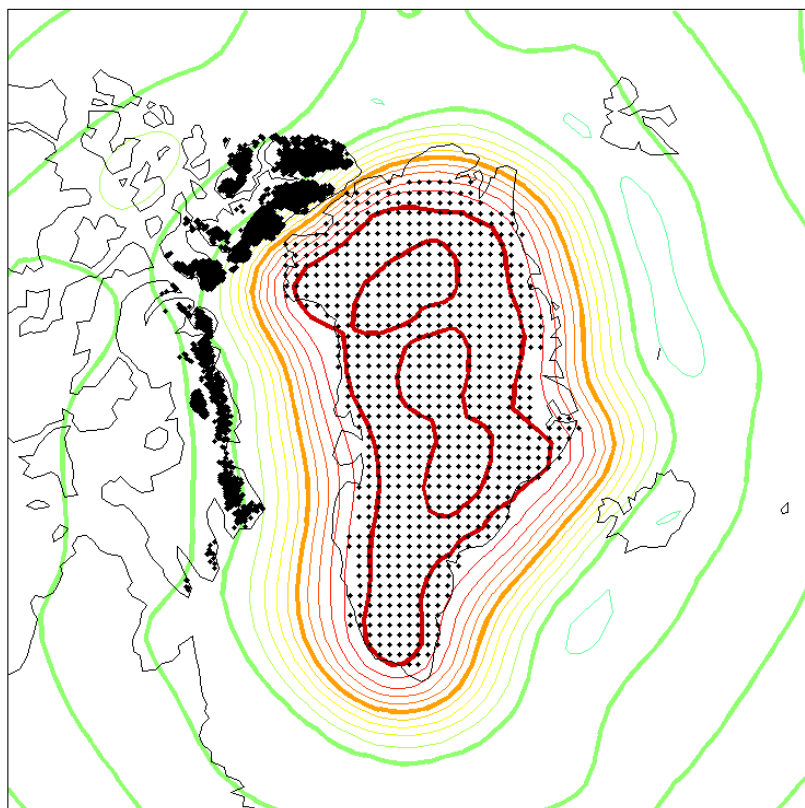
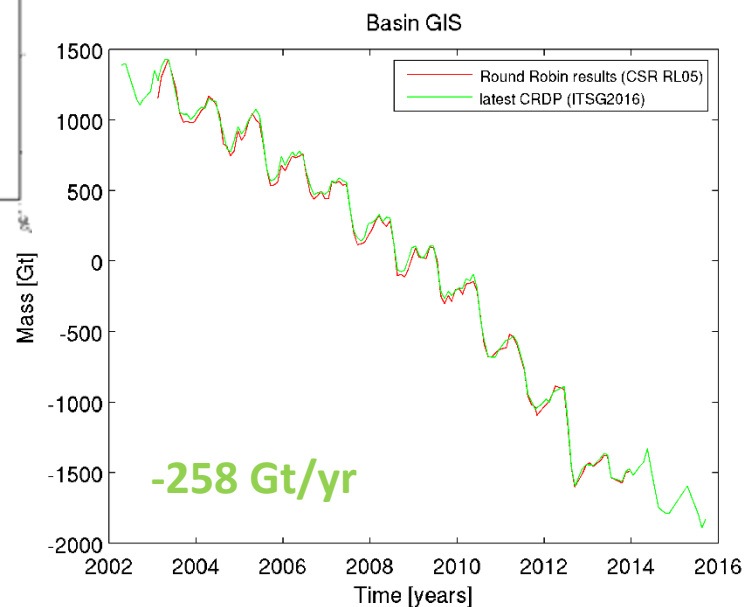
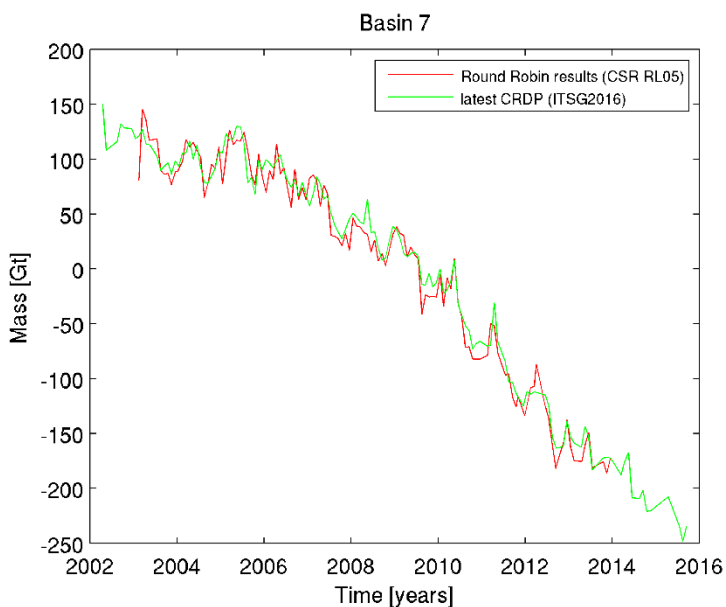
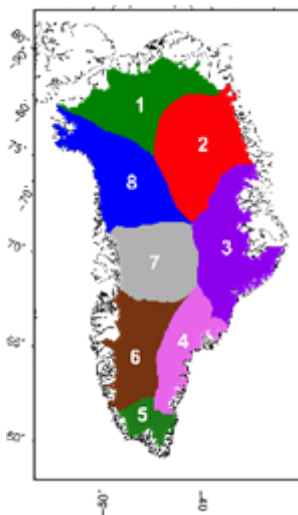
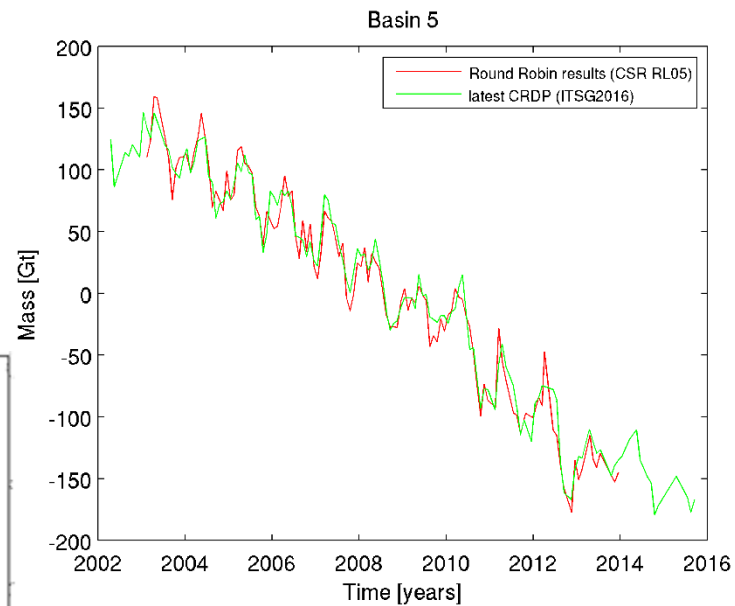
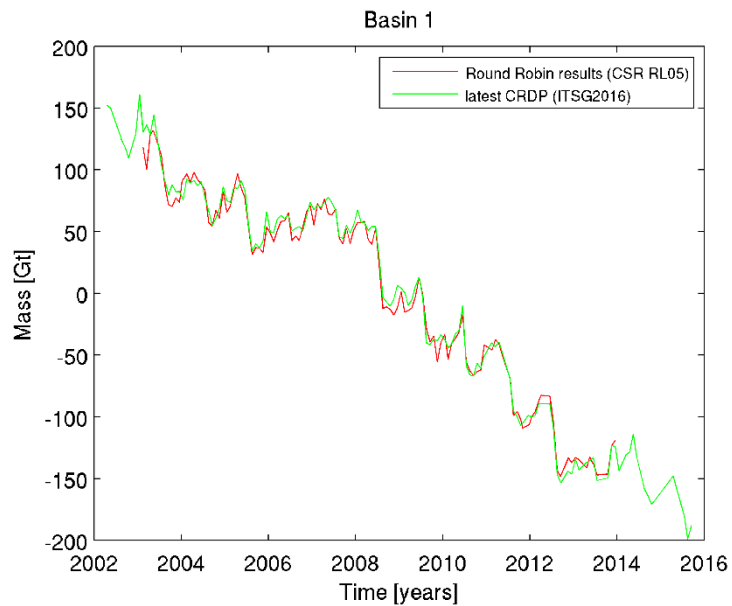

Figure 8.2: Illustration indicating that Gaussian smoothing not only reduces noise in the signal, but also removes a large part of the signal contained in the monthly solutions. This is the geopotential anomaly from the GSM product during June 2013.

(Tim Jensen)

Sensitivity kernels – regional mass loss





(A. Groh, TU Dresden – ESA CCI)

Converting gravity change to ice mass change by point mass inversion

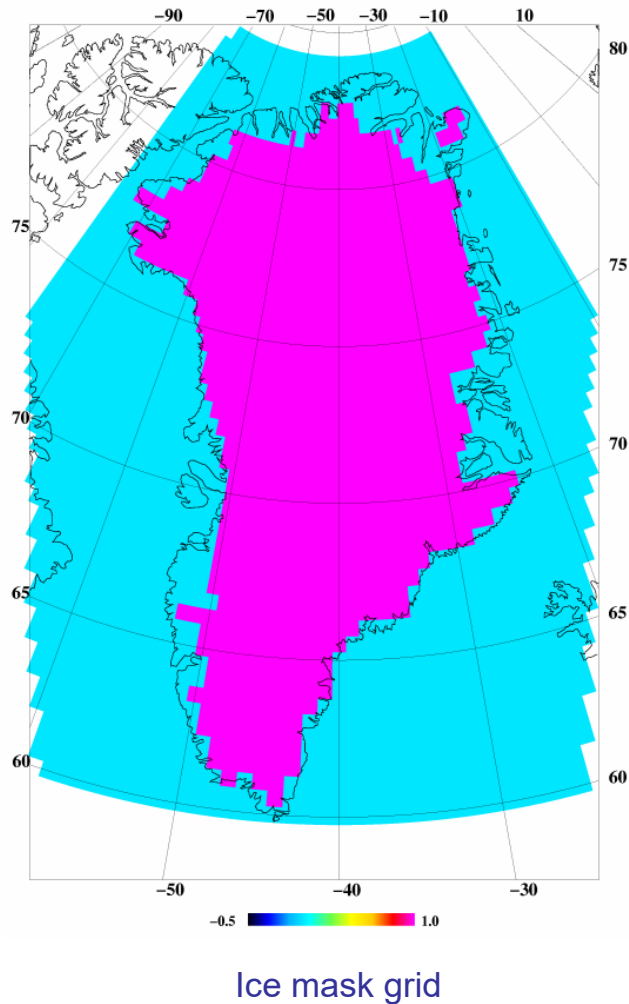

Obs. $\underline{y} = \{\delta g_i\}$, $i = 1, \dots, n$ at altitude (grid)

Modelpar. $\underline{x} = \{m_j\}$, $j = 1, \dots, m$ at surface,

$$\delta g_i = Gm_j \frac{R^2 r - R^3 \cos \psi}{[r^2 + R^2 - 2Rr \cos \psi]^{3/2}}$$

Model masscons only in Greenland area ..
assuming no signal from ocean

Obs.eq. $\underline{y} = A\underline{x}$... *need regularization*

Generalized inverse $\underline{x} = [A^T A + \lambda I]^{-1} A^T \underline{y}$
-> dM/dt (Tychonov regularization)

This is a *generalized inverse* ..

Least squares estimate for properly posed problem ($n > m$): $\underline{x} = [A^T A]^{-1} A^T \underline{y}$

Greenland mass trends 2002-10 .. basins and time

*Refined analysis (Barletta/Forsberg):
Solve for multiple ice sheets
GIA, elastic, low-order harmonics corr.*

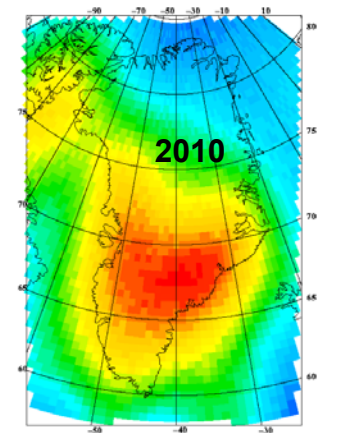
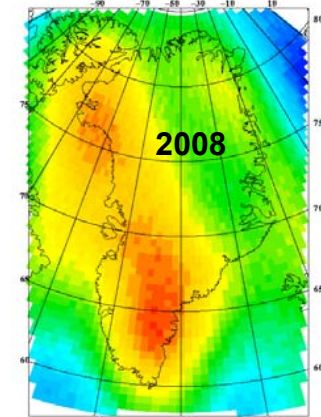
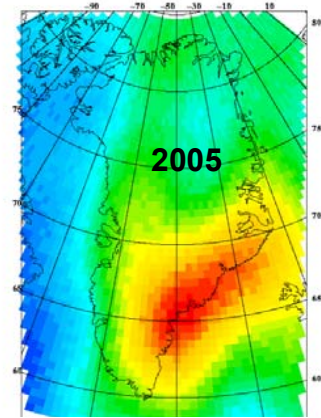
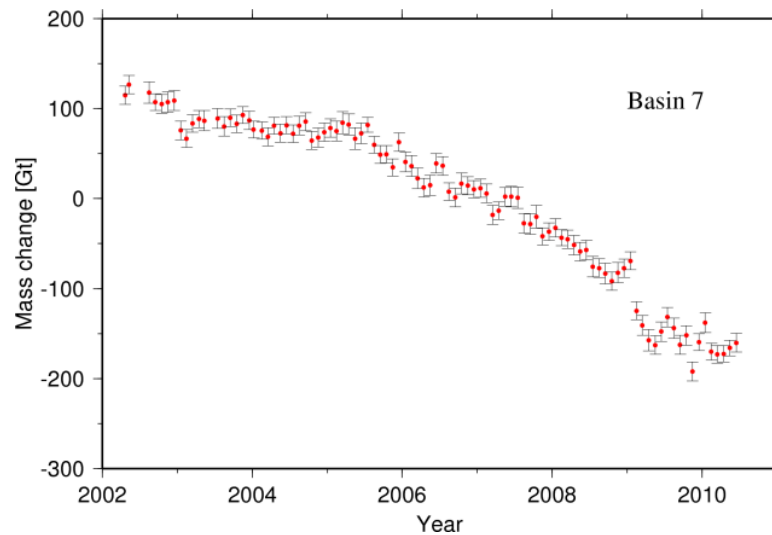
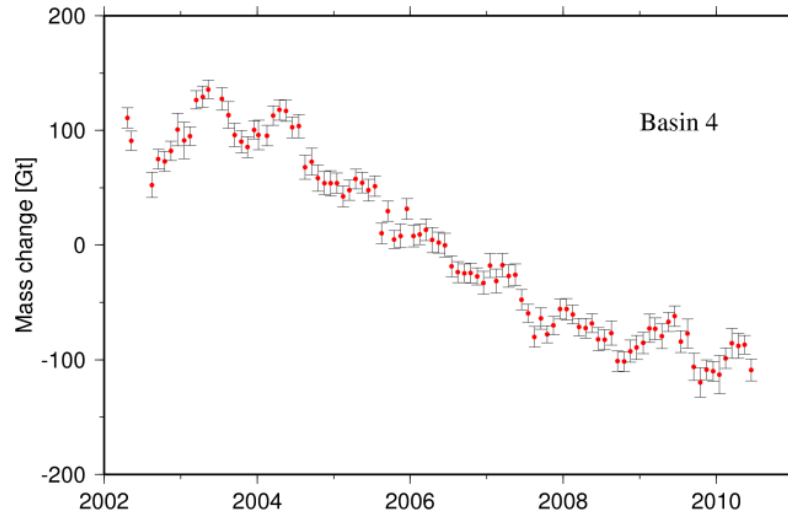
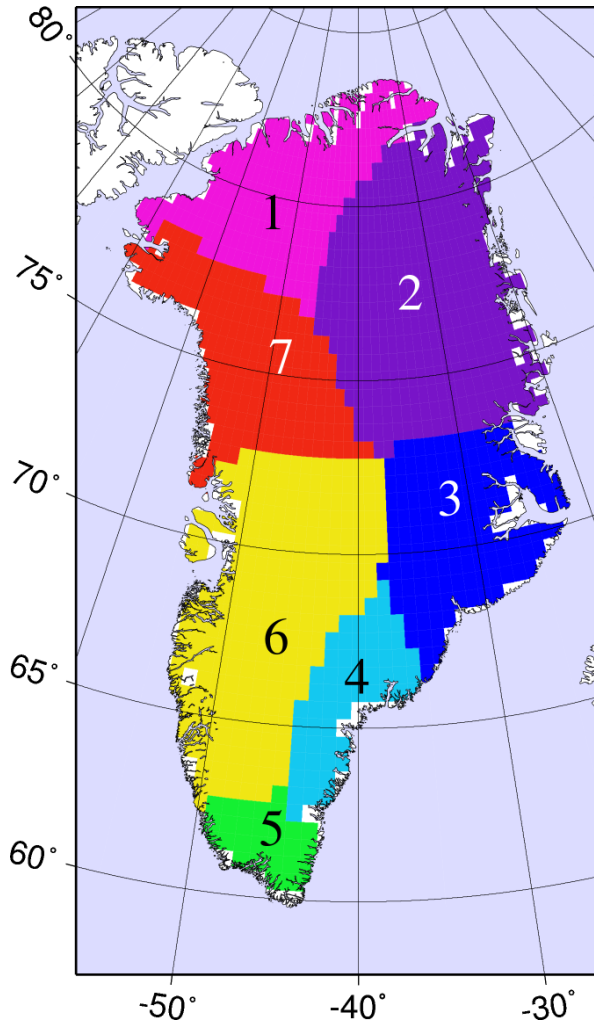

NASA Grace solutions – solving directly for masscons from L1 range/range-rate data (Lutsche et al 2006)

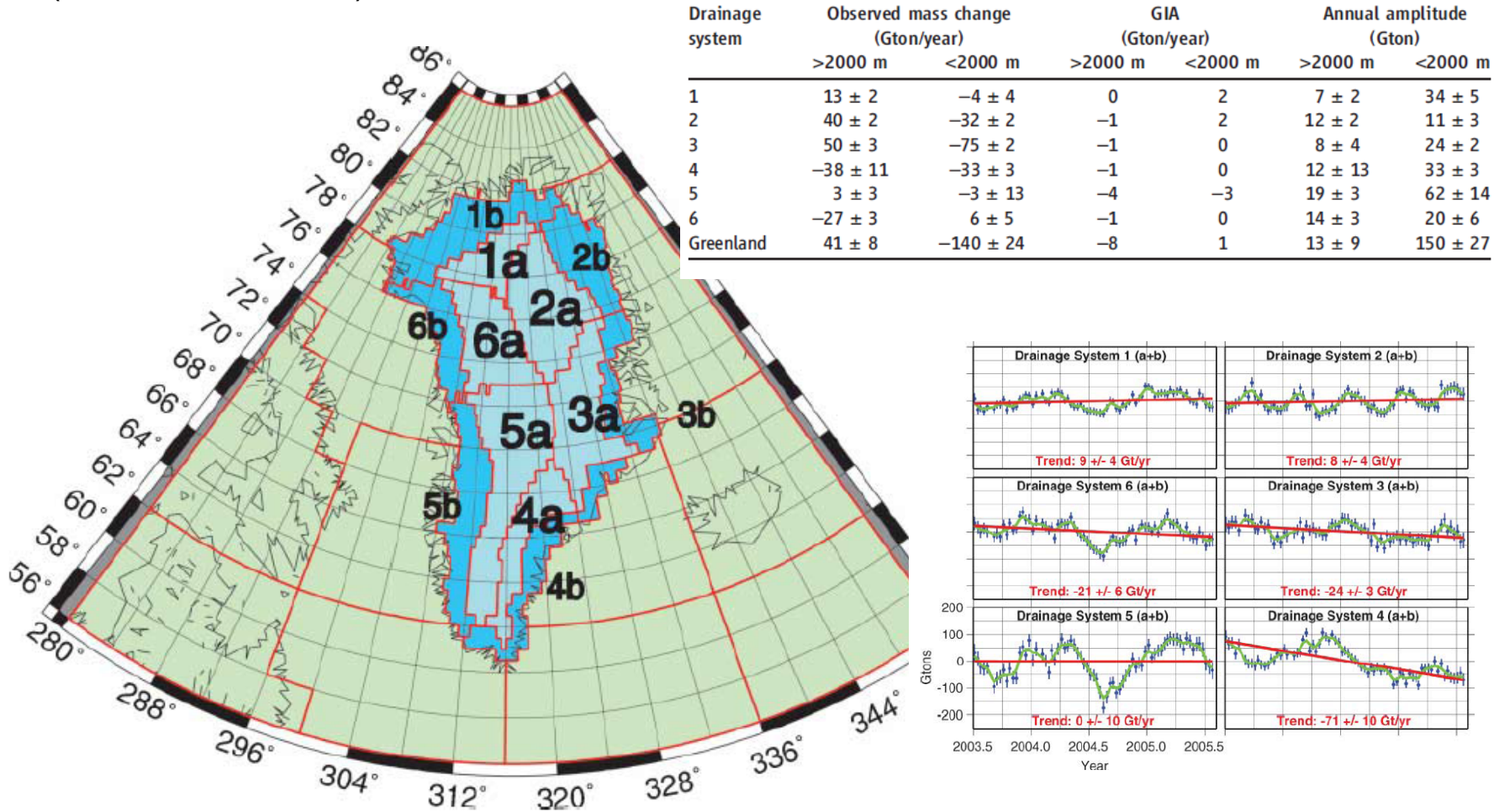

Fig. 1. Greenland DS mascon regions: regions above 2000 m elevation are labeled "a," and those below are labeled "b." Exterior region mascons outside of Greenland are also shown outlined in red.

Examples: Analysis of GRACE ice sheet data

Data: Monthly spherical harmonic solutions (Release 4):
 CSR [Center for Space Research, University of Texas]
 GFZ [Geoforschungszentrum, Germany]
 ITSG [TU Graz] – new reprocessed data 2016
C20-term substituted with SLR values

Processing:

- Expansion to harmonic degree $N = 30$ or 60
Degree 60 corresponds to 3° resolution

$$T(r, \varphi, \lambda) = \frac{GM}{R} \sum_{n=2}^N \sum_{m=0}^n [\bar{C}_{nm} \cos m\lambda + \bar{D}_{nm} \sin m\lambda] \bar{P}_{nm}(\sin \varphi)$$

- Potential fields: geoid N or gravity disturbance δg equivalent,
 function of potential T (units: mm or $\mu\text{gal} = 10^{-8} \text{ m/s}^2$)

$$N = \frac{T}{\gamma} \quad \delta g = \frac{\partial T}{\partial r}$$

- 4-parameter trend and seasonal analysis: $dg(t) = a + b t + c \cos(\omega t) + d \sin(\omega t)$

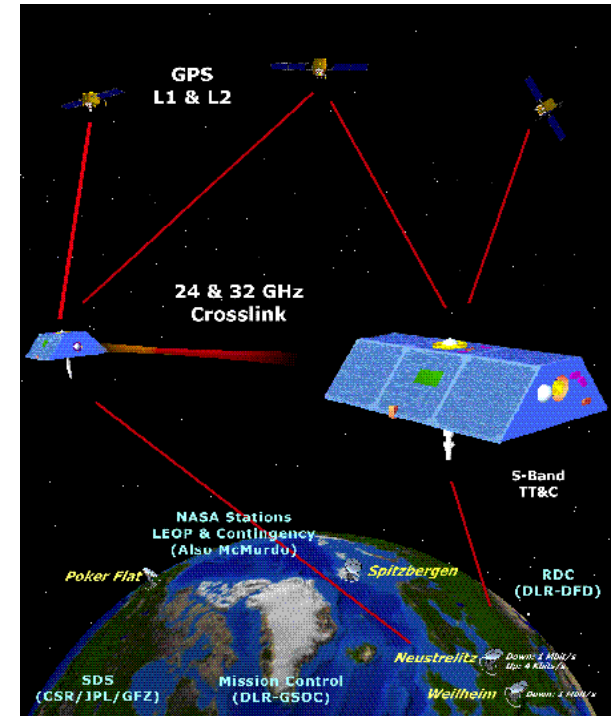

Global analysis – yearly trend 2002-14 (CSR RL5 dg at 480 km, deg 60)

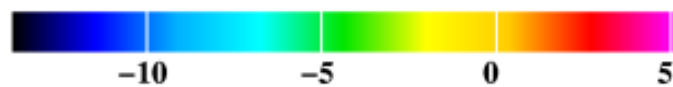
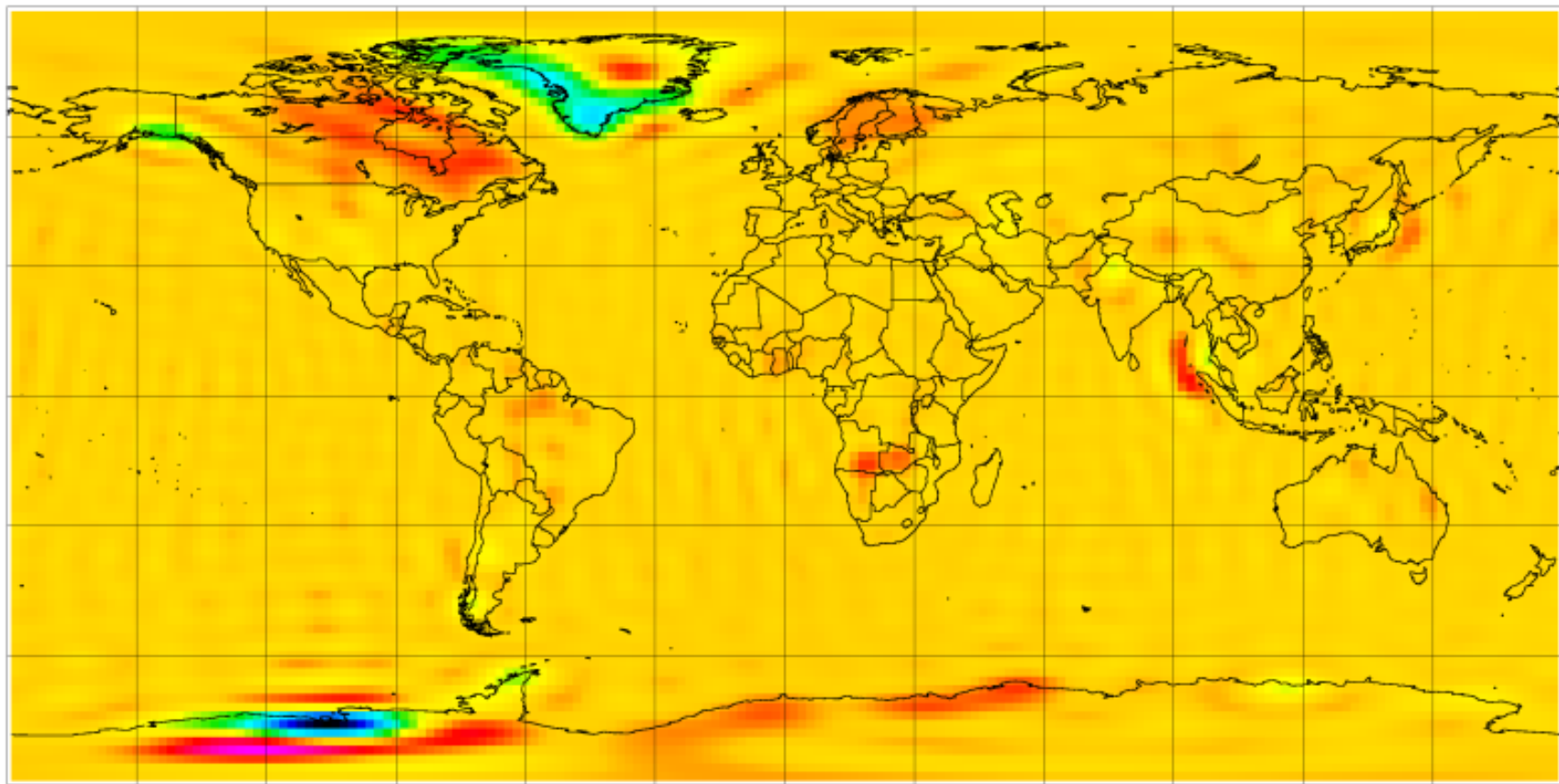

Units: $10^{-9}g$ (μgal)

Global analysis – yearly amplitude 2002-14 (CSR RL4 dg at 480 km, deg 60)

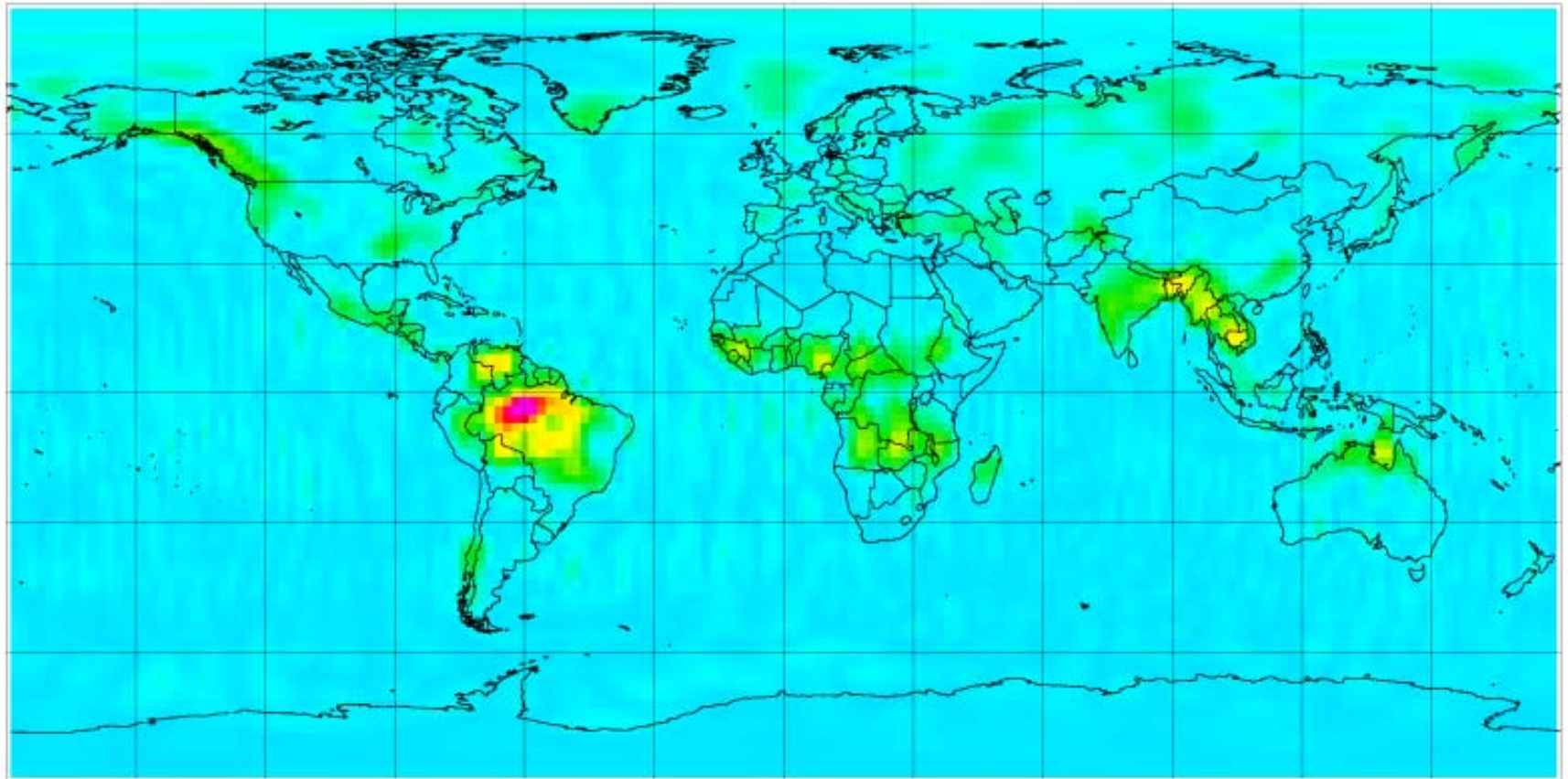

Units: $10^{-9}g$ (μgal)

Greenland and Antarctica zoom-in (ITSG 2002-16)

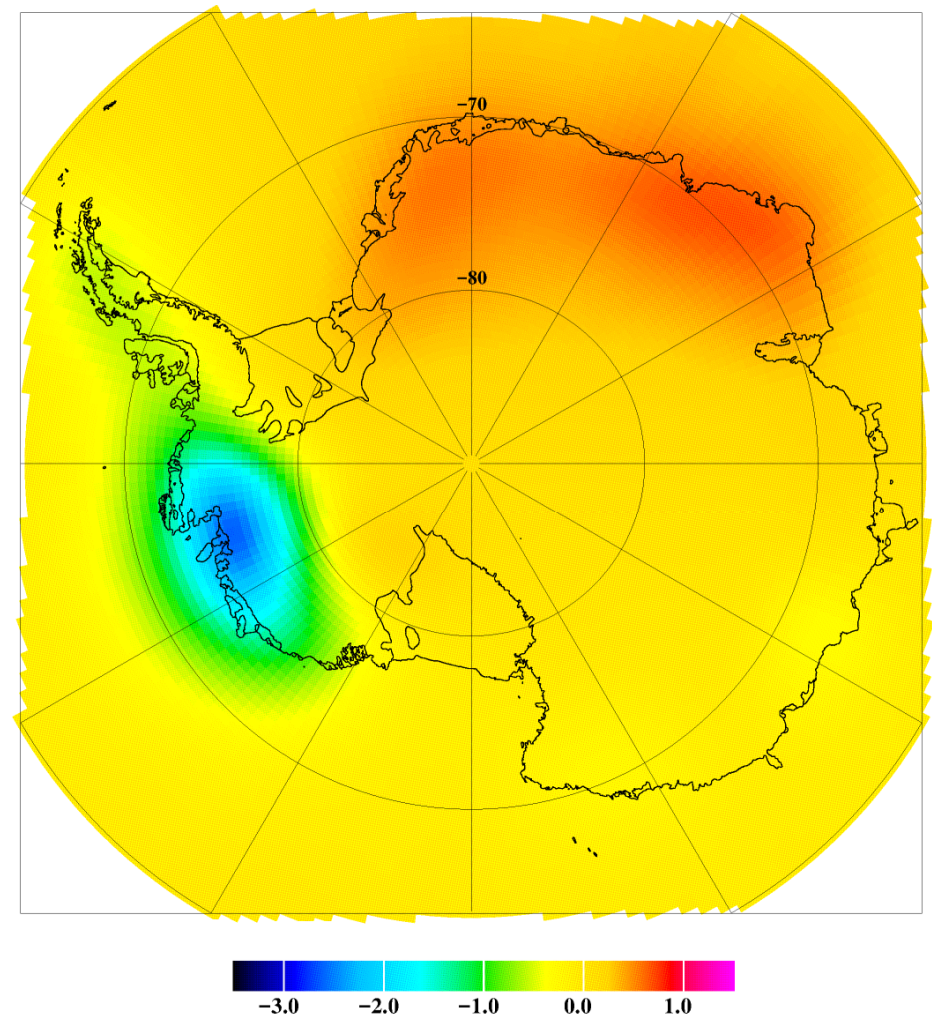
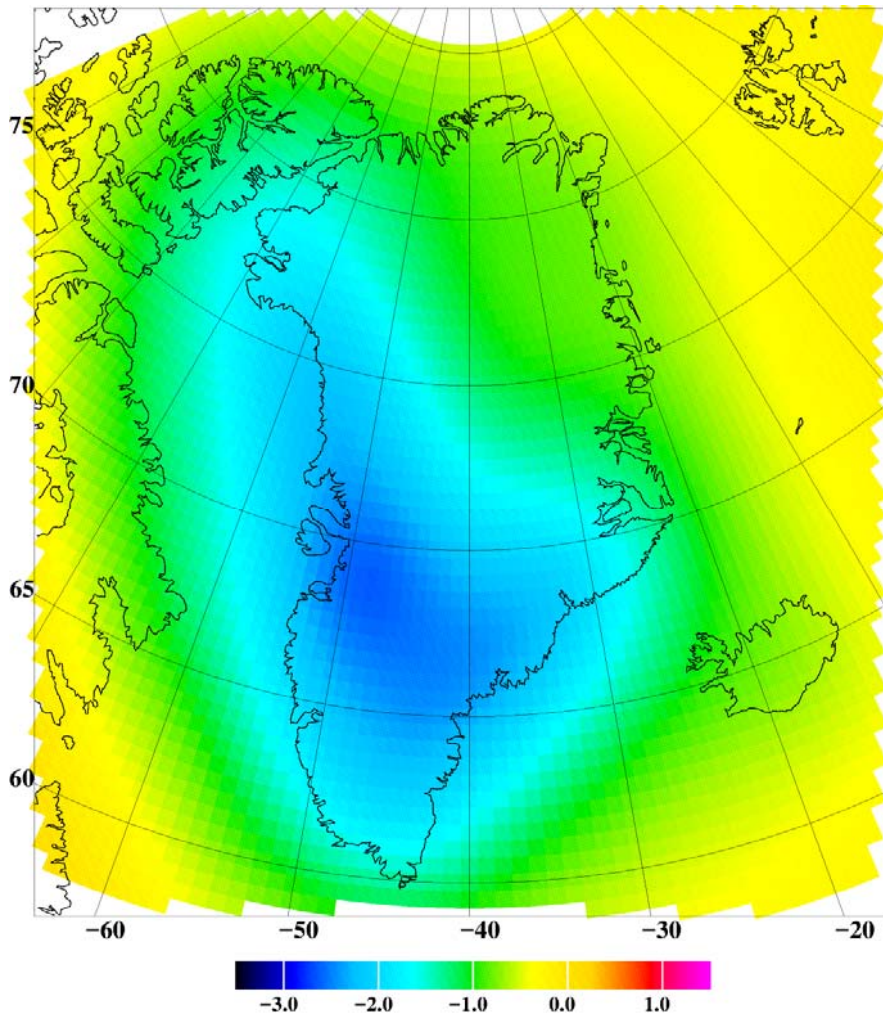

Gravity trends at altitude ($\mu\text{Gal}/\text{yr}$)

Annual signals and yearly accumulation - Greenland

Annual signal (CSR 2002-14, $\mu\text{gal}/\text{year}$)

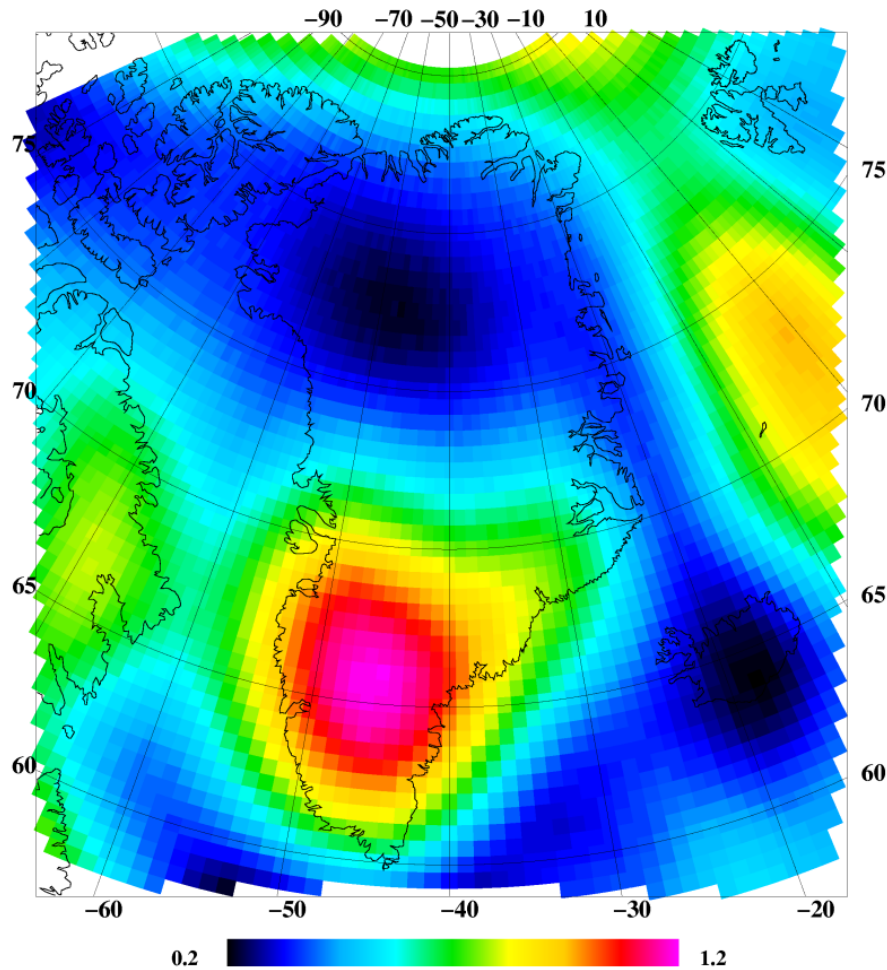

Average snow accumulation (mm ice-equivalent/yr, scale 0-800)

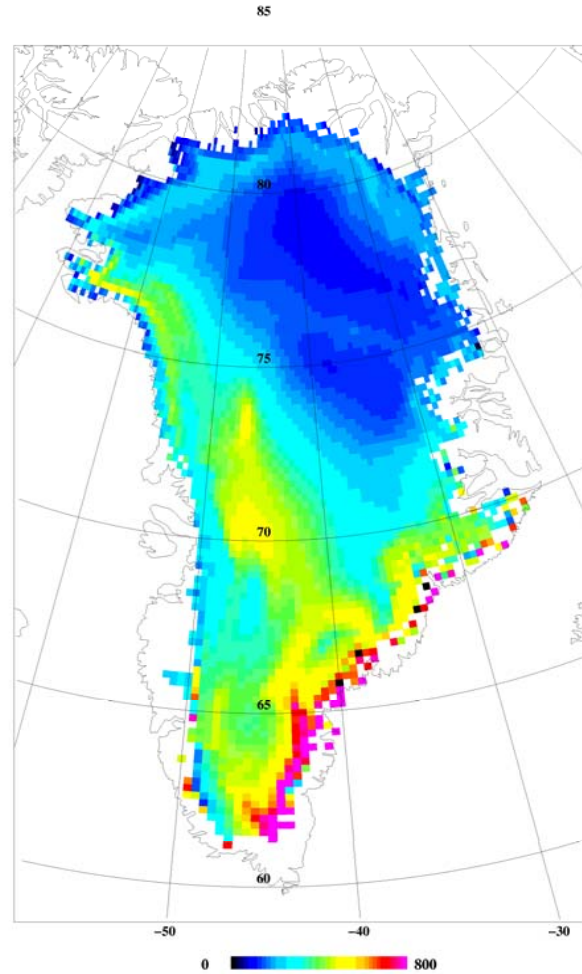

Greenland – higher resolution possible in trend due to stacking

degree 60

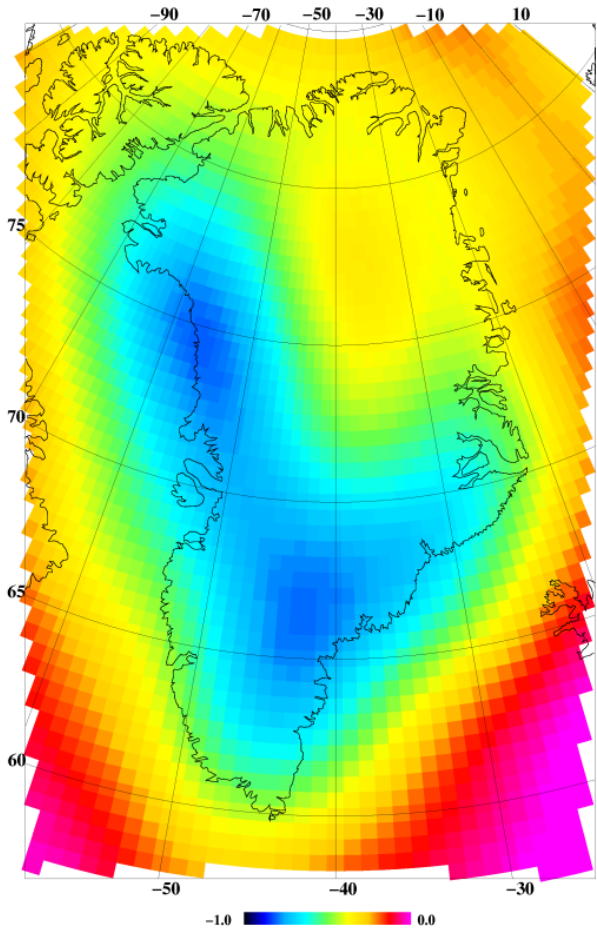

GFZ RL4
degree 90

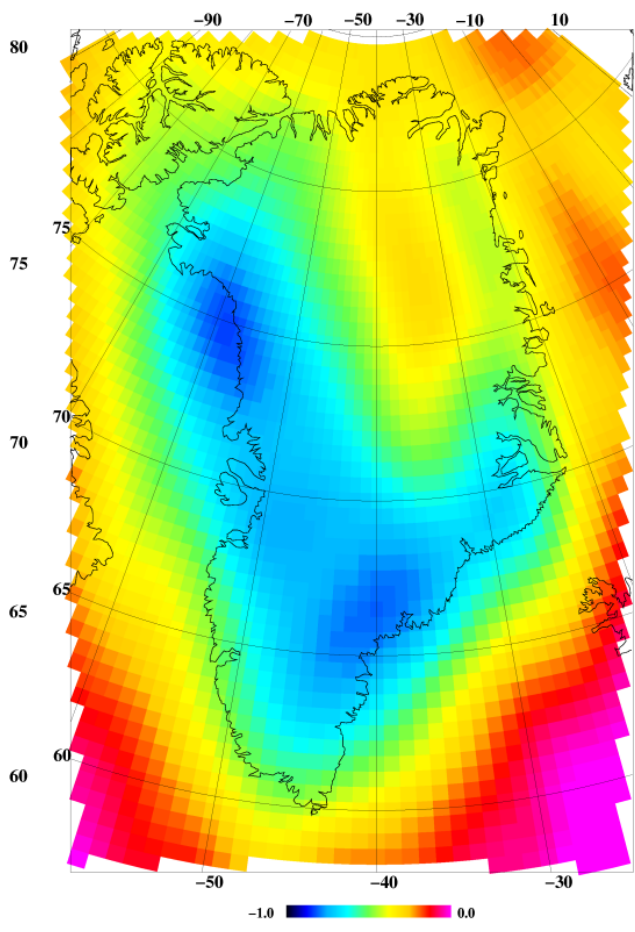

degree 120

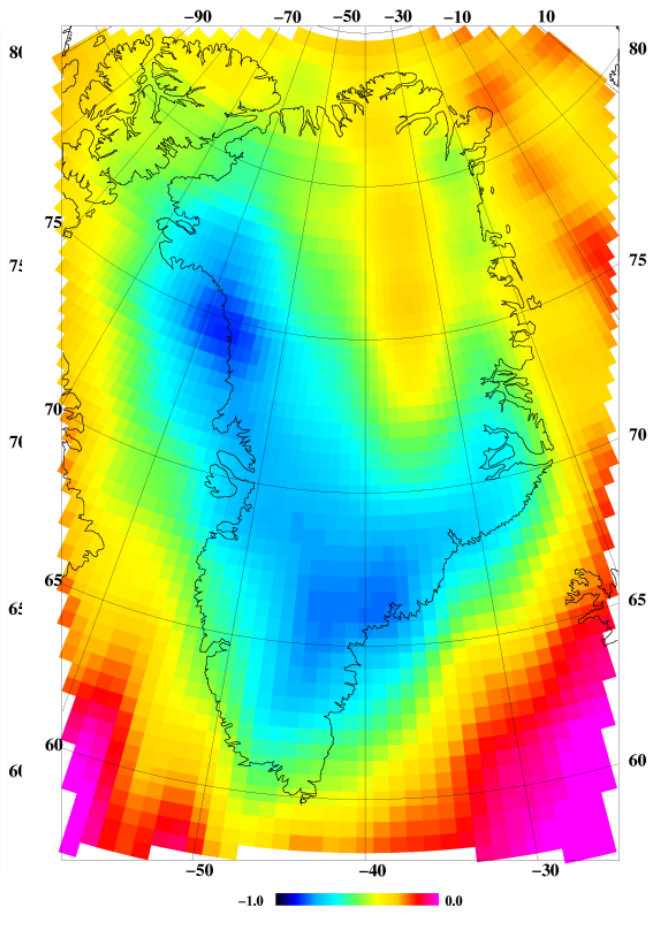

GRACE pointmass solutions - indicator grids, apriori ice mass elements

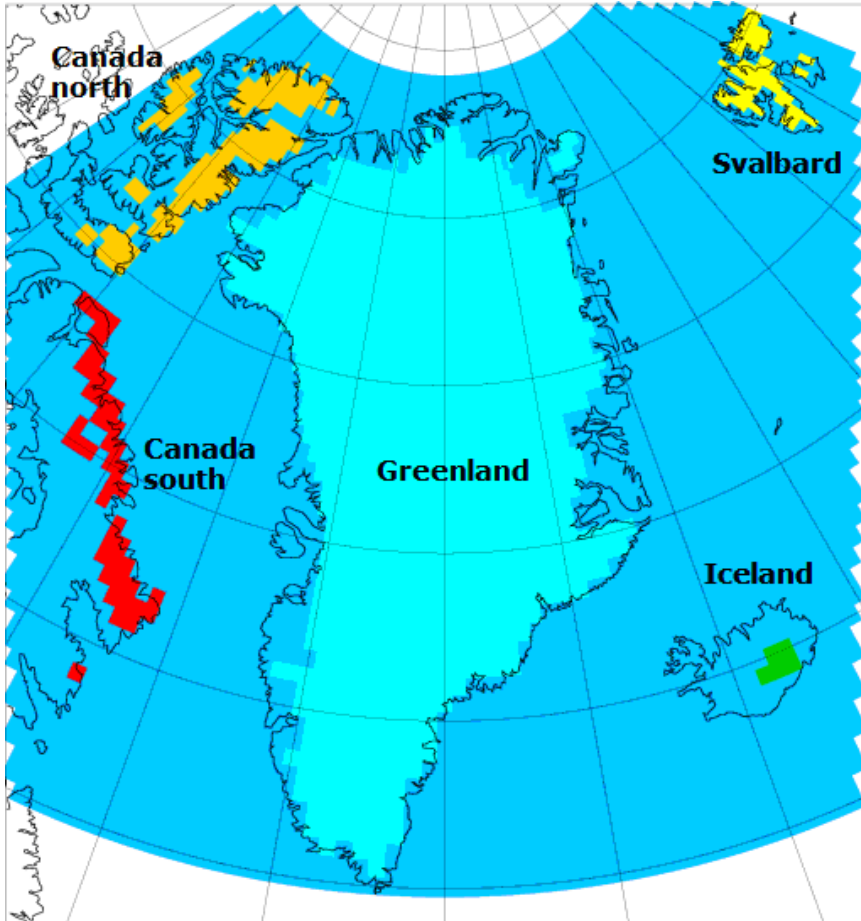

Leakage from neighboring ice caps a special problem in Greenland ..

GRACE pointmass (mascon) solutions (CSR 2002-14, deg 60)

Greenland and arctic ice caps

Solving for Greenland only

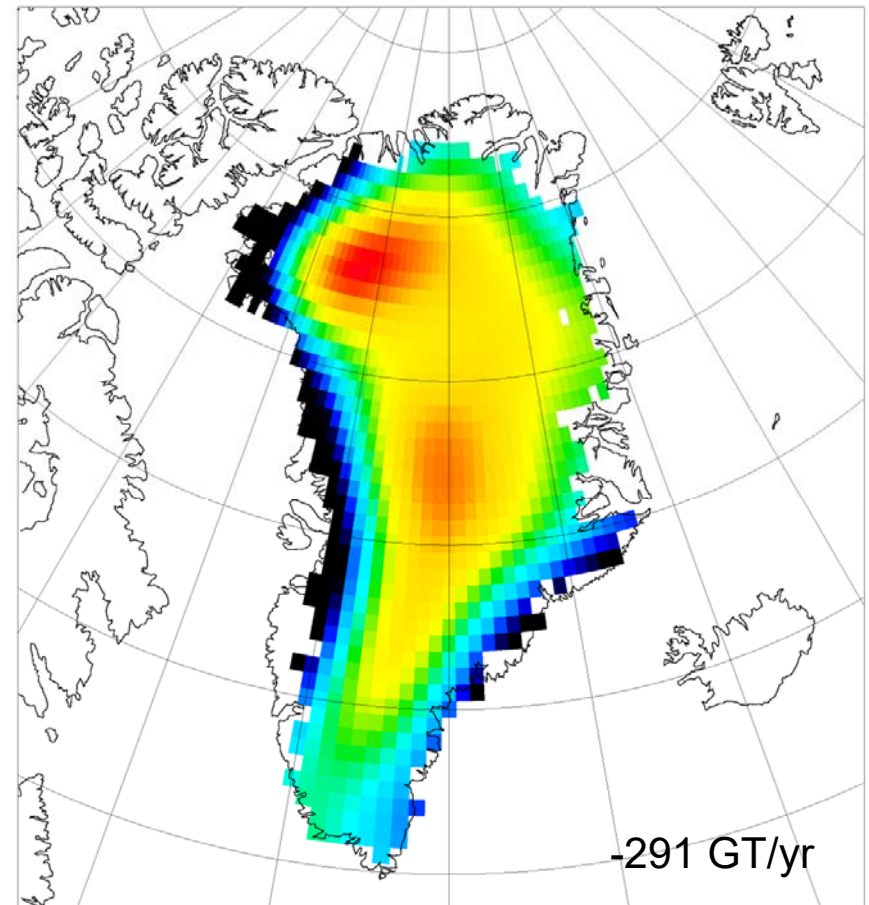
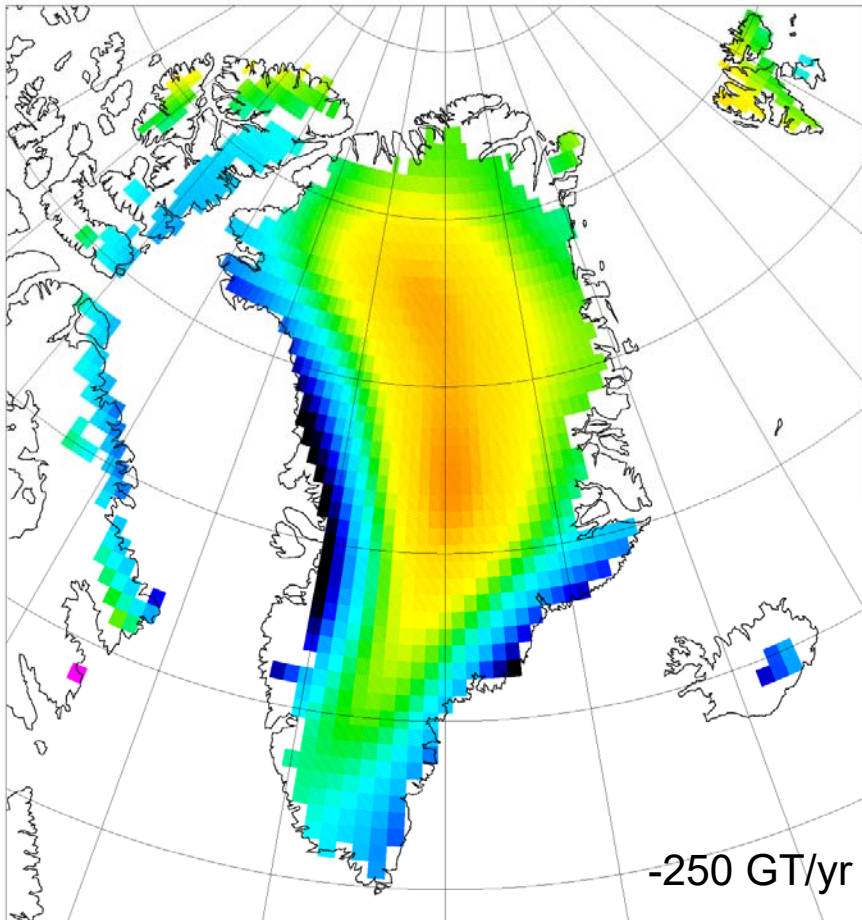

mm water-eq./year

Pointmass solutions - total mass loss trends

Antarctica clear
acceleration

Greenland less so
due to 2012 melt event

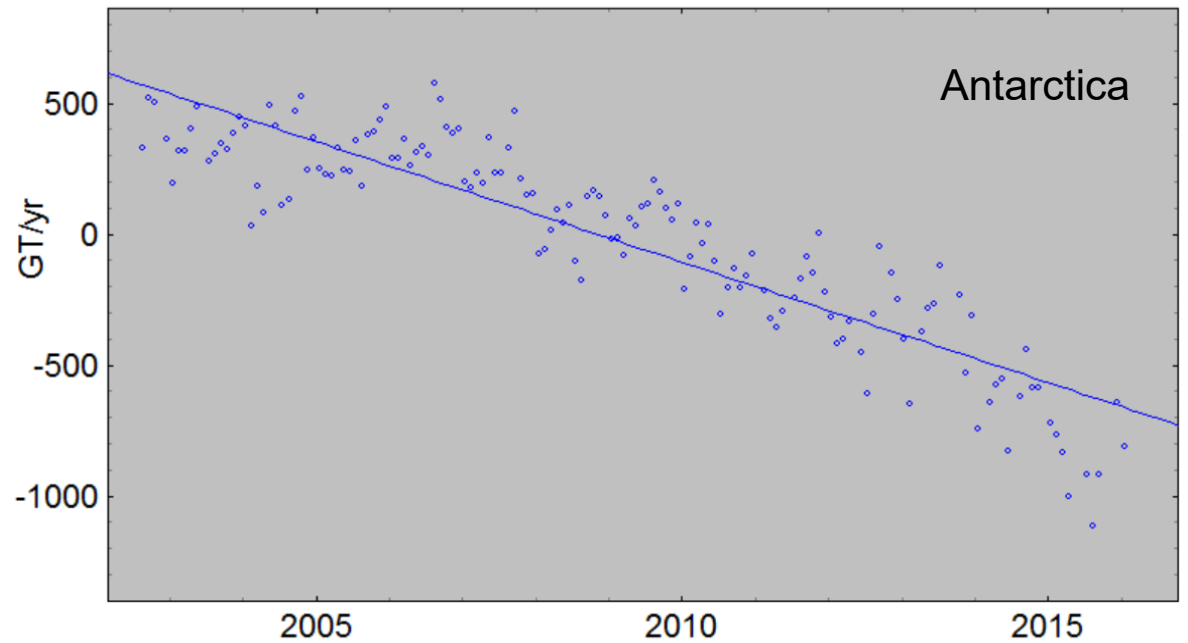
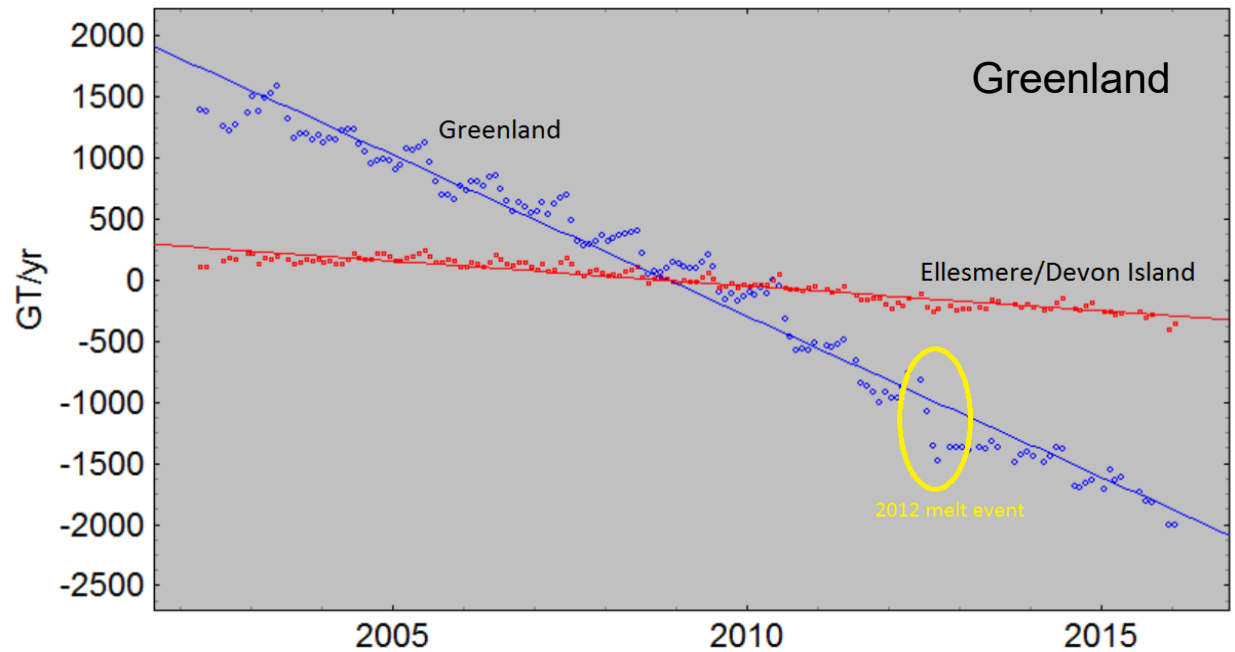

Pointmass solutions: Trends 2002-16 (ITSG, deg 90, GIA: ICE-5G grl./W12 ant.)

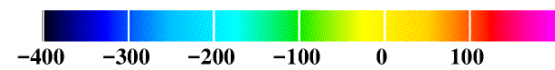
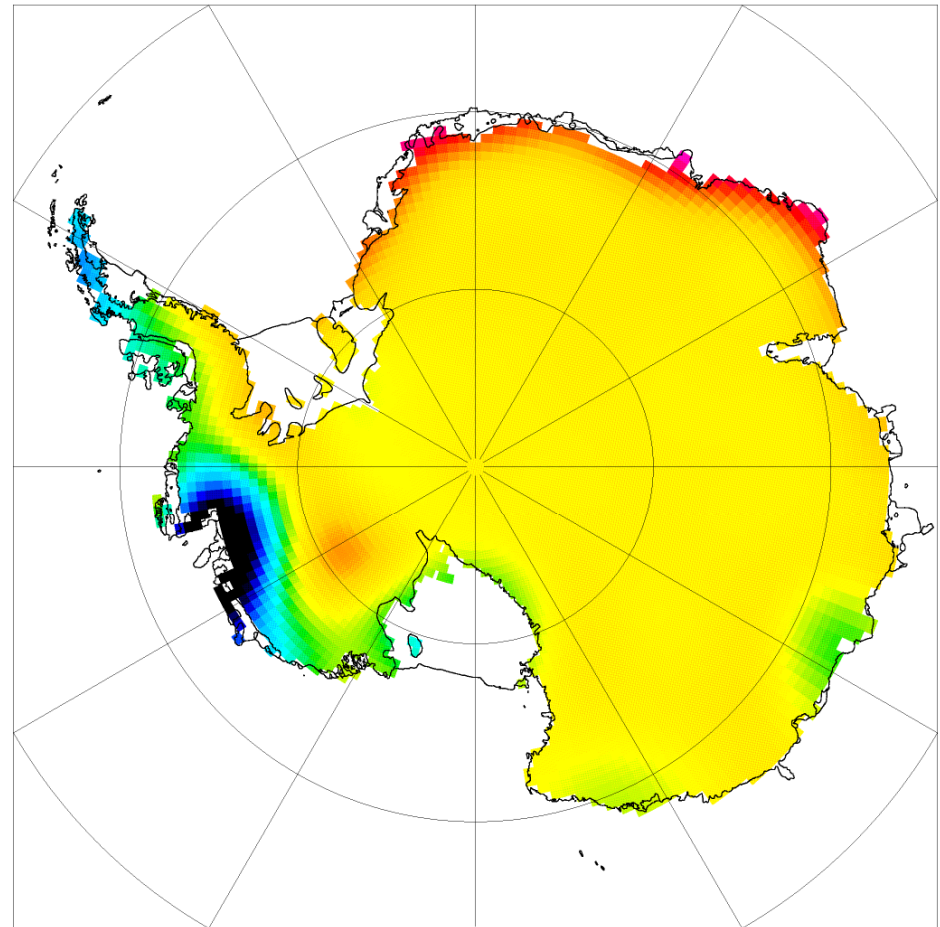
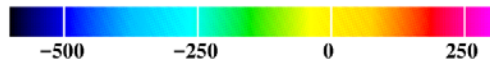
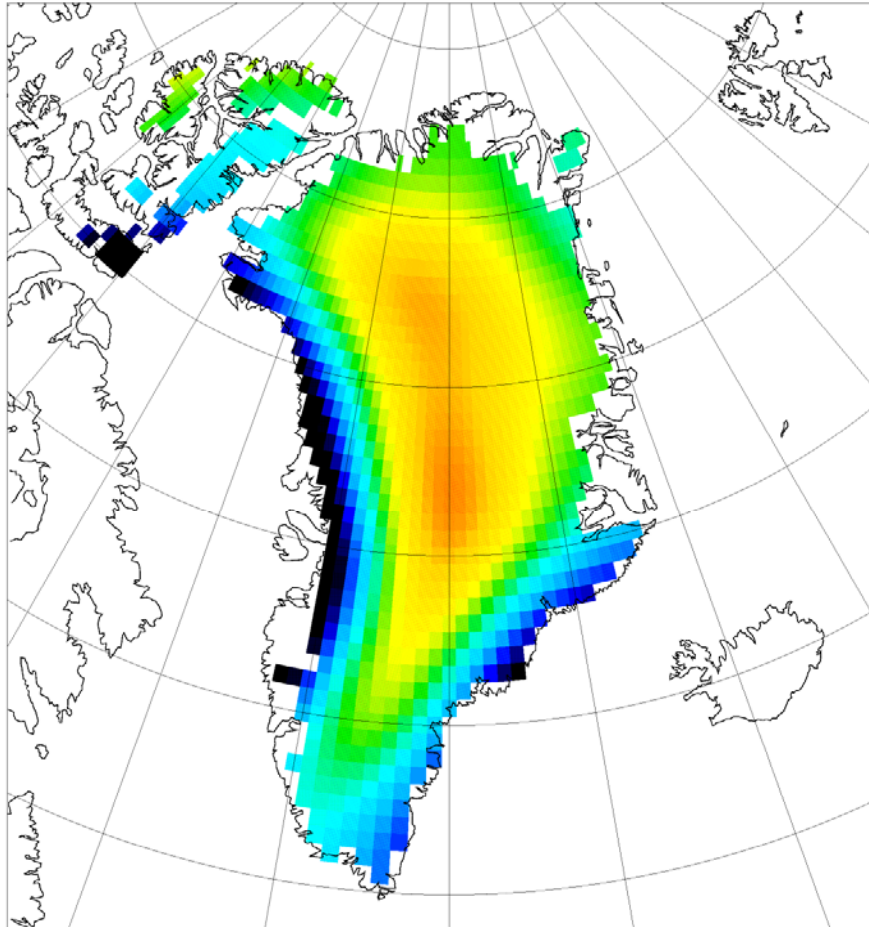

Pointmass solutions: ITSG trends 2002-16 and global sea level rise

Time period	Apr 2002-15 (13.7 yrs)		2006-15 (10 years)		2011-15 (5 years)	
	GT/yr	mm/yr	GT/yr	mm/yr	GT/yr	mm/yr
Greenland, incl. outlying ice caps (± 25 GT/yr)	-264	-0.72	-295	-0.80	-265	-0.72
<i>Ellesmere and Devon Island</i> ** (± 20 GT/yr)	-41	-0.11	-48	-0.13	-45	-0.12
Antarctica* (± 50 GT/yr)	-92	-0.25	-120	-0.33	-147	-0.40

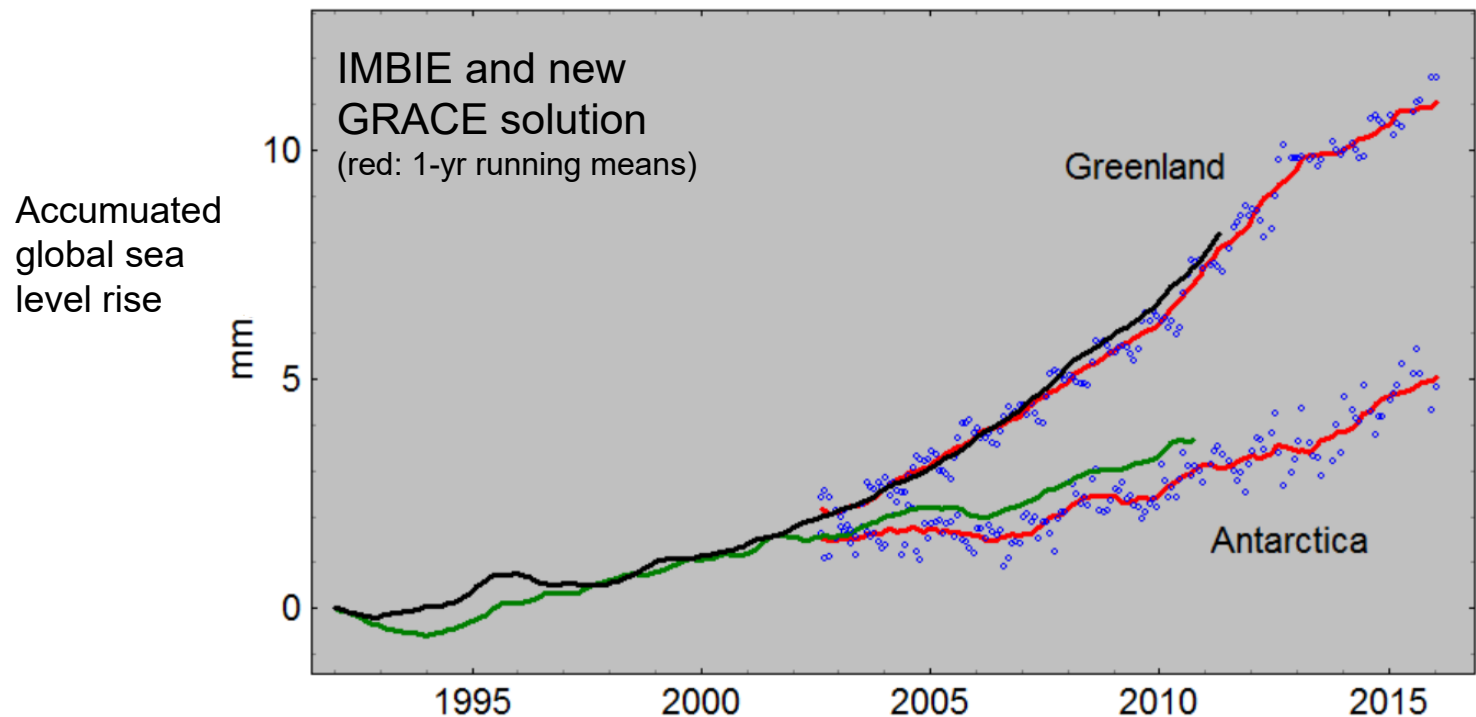

IMBIE 2011-12: International Mass Balance Intercomparison Experiment

NASA/ESA joint project .. consensus of space methods for Antarctica and Greenland for IPCC

GRACE: Wahr, Velicogna, Schrama, Lutsche, Horwath, Bettadpur, Forsberg/Barletta ...

Altimetry (IceSat/Envisat): Wingham, Zwally, Pritchard, Shephard, Ben Smith, Louise ..

GIA: Ivins, Milne, Whitehouse, Barletta ..

SMB: Van der Brooke, Luckman, Bromwich, Scampos ..

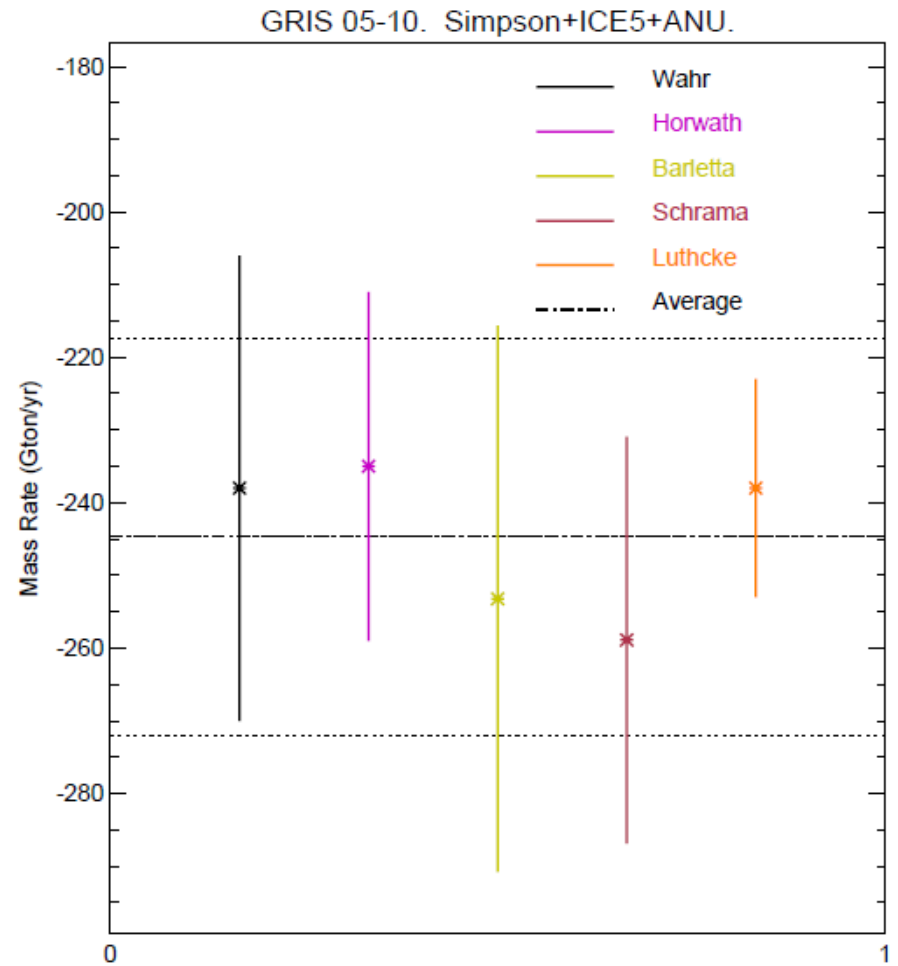
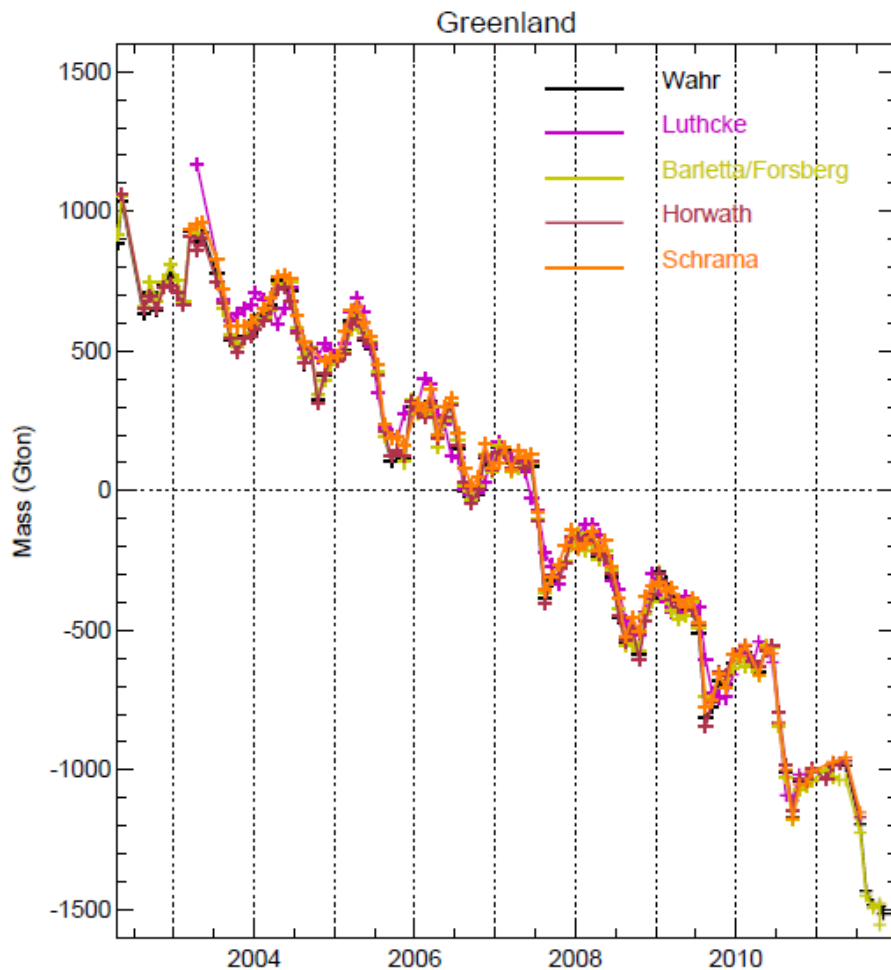

The "real" mass loss regions – laser (IceSat 2003-9)

Repeat track algorithm [L. Sørensen]

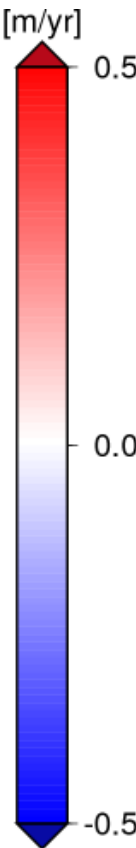
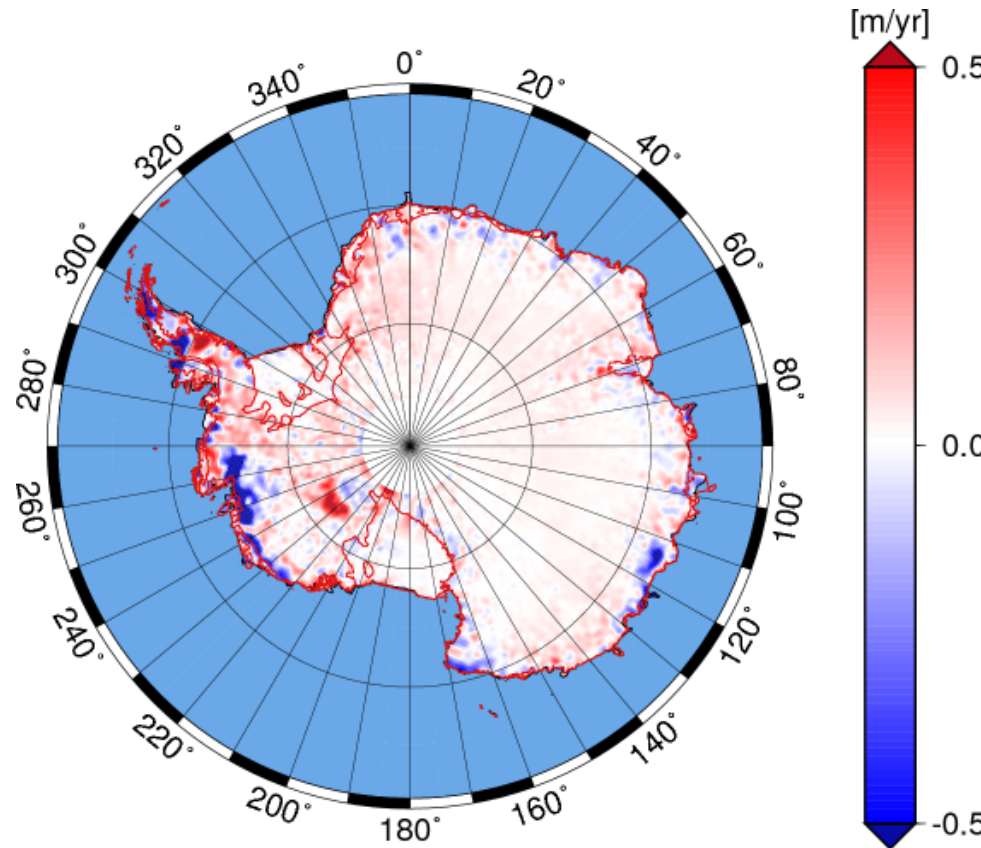
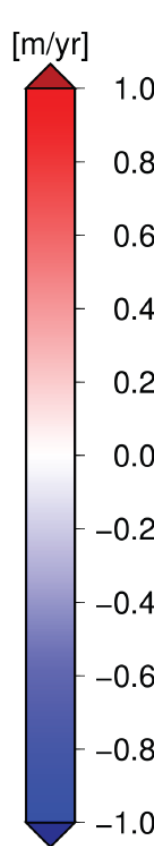
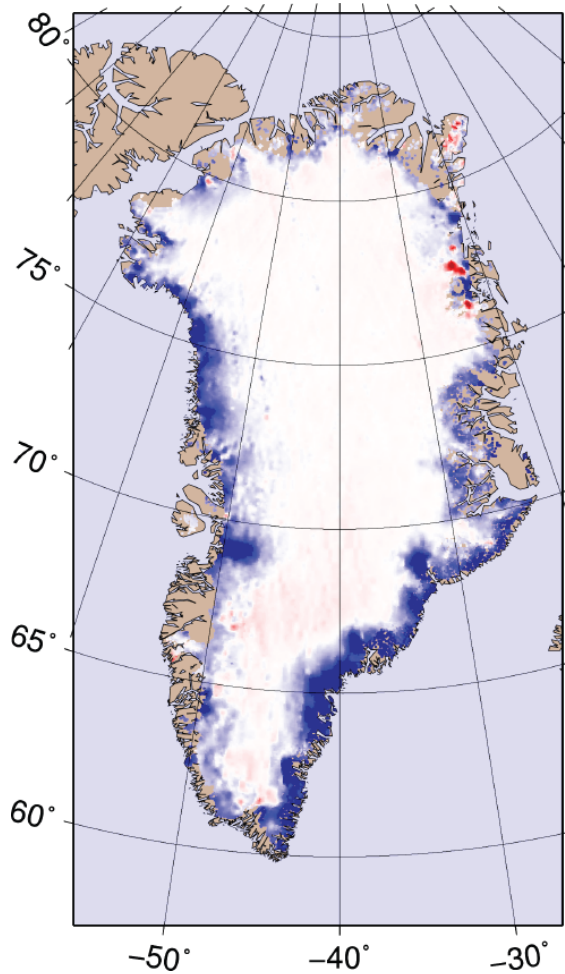

*Challenge: Conversion of dh/dt to mass change
Ice density: 0.92 g/cm^3 ... firn $0.3-0.35 \text{ g/cm}^3$*

Greenland GRACE 2003-9

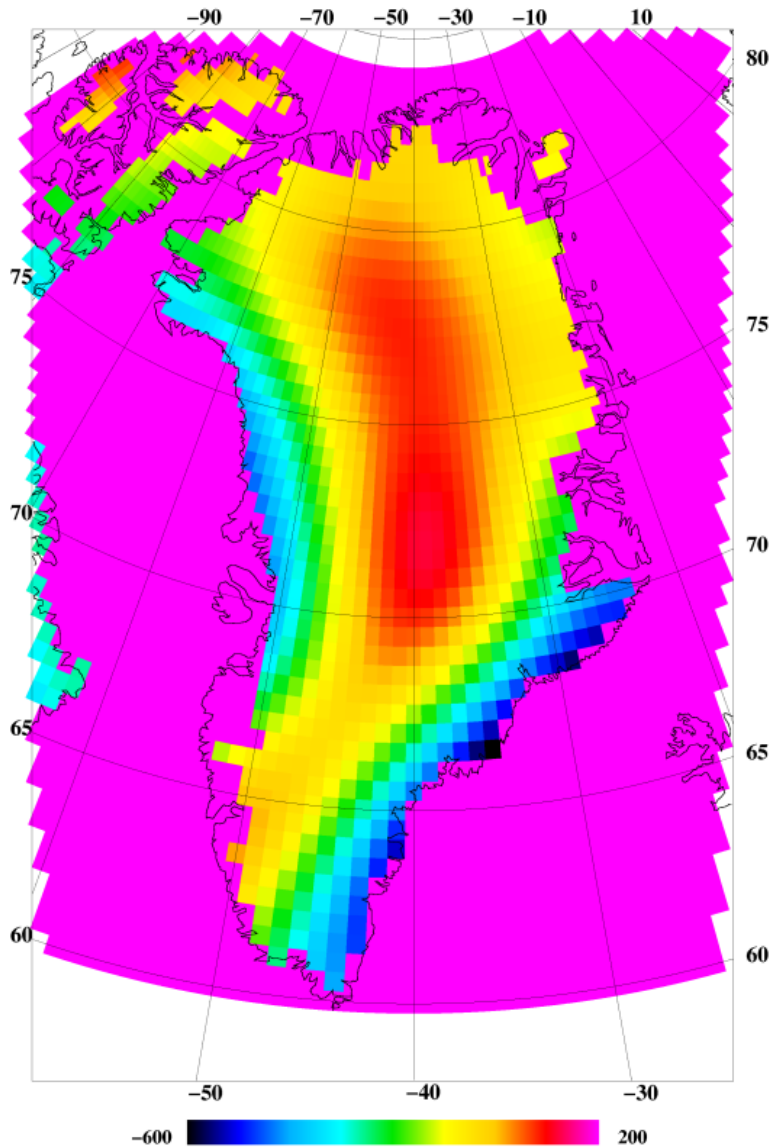

IceSat filtered to GRACE resolution

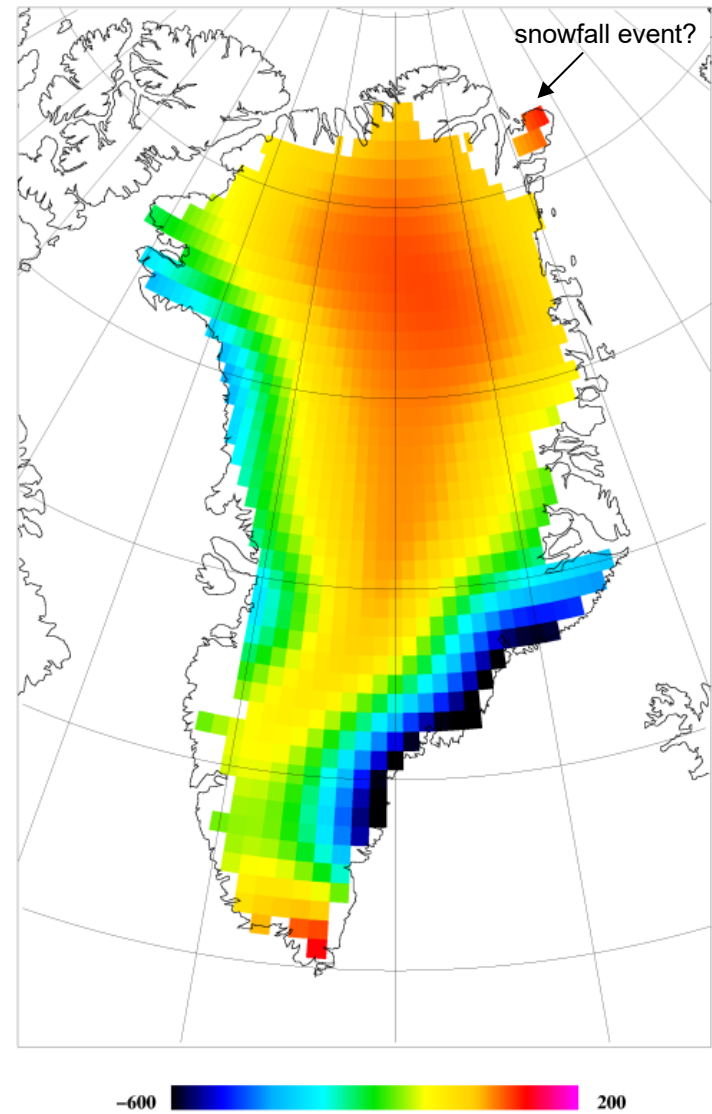

mm water equivalent

Antarctica GRACE

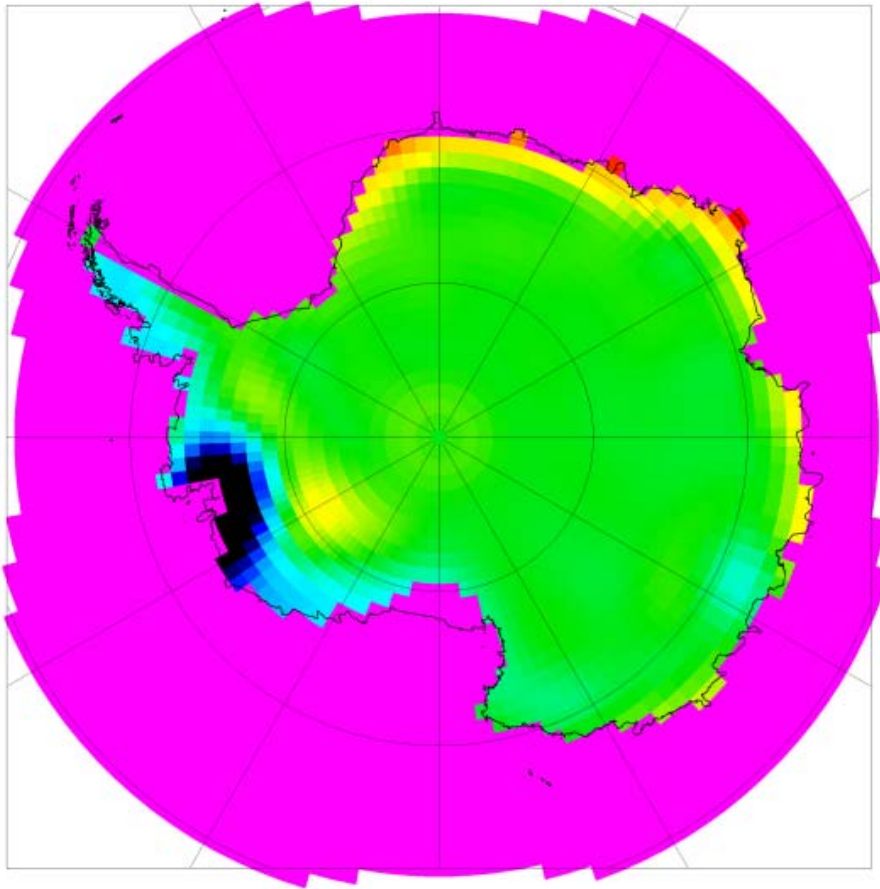

IceSat filtered to GRACE resolution

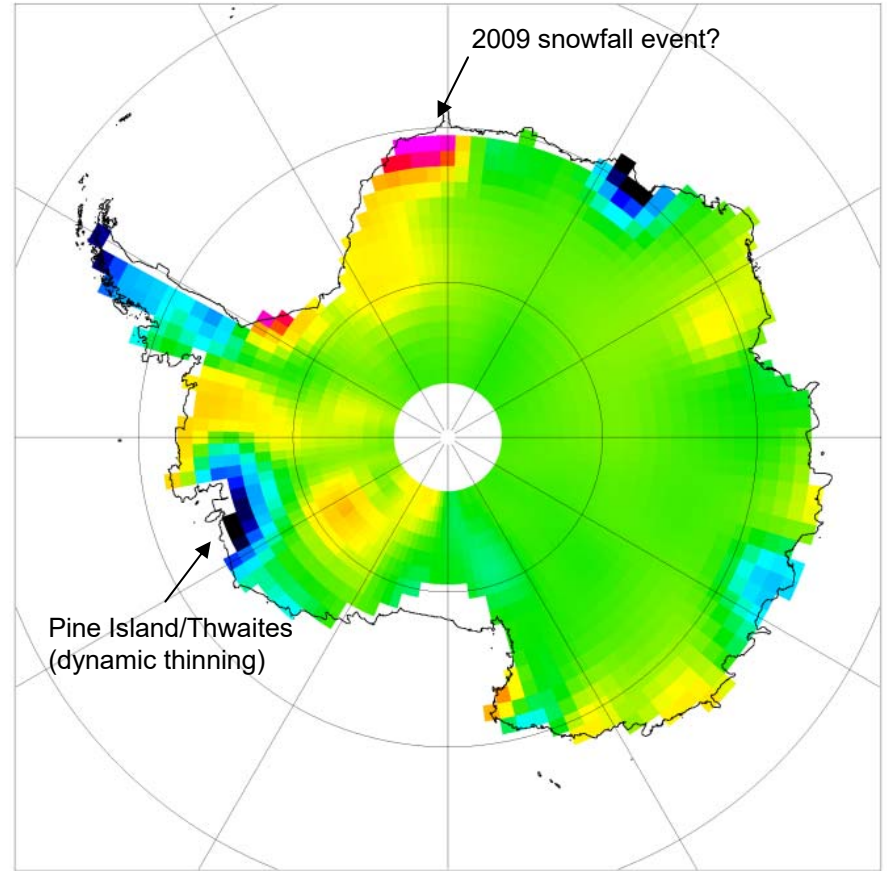

Pine Island/Thwaites
(dynamic thinning)

2009 snowfall event?



mm water equivalent

Mass and elevation changes - Greenland

CryoSat 2010-14

Envisat 2002-10

GRACE 2002-14

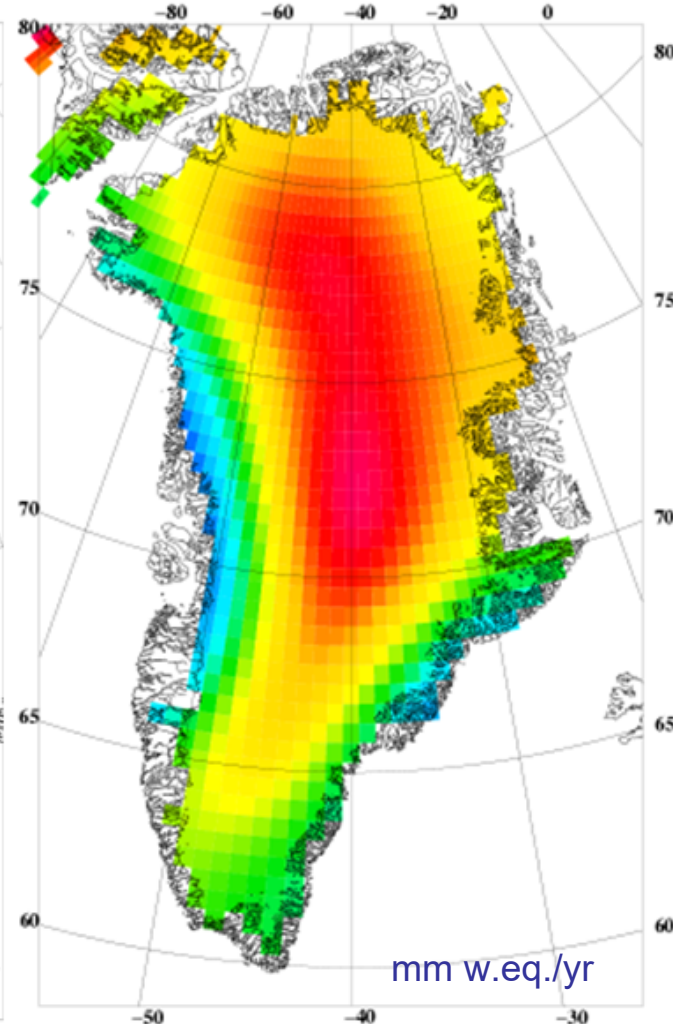
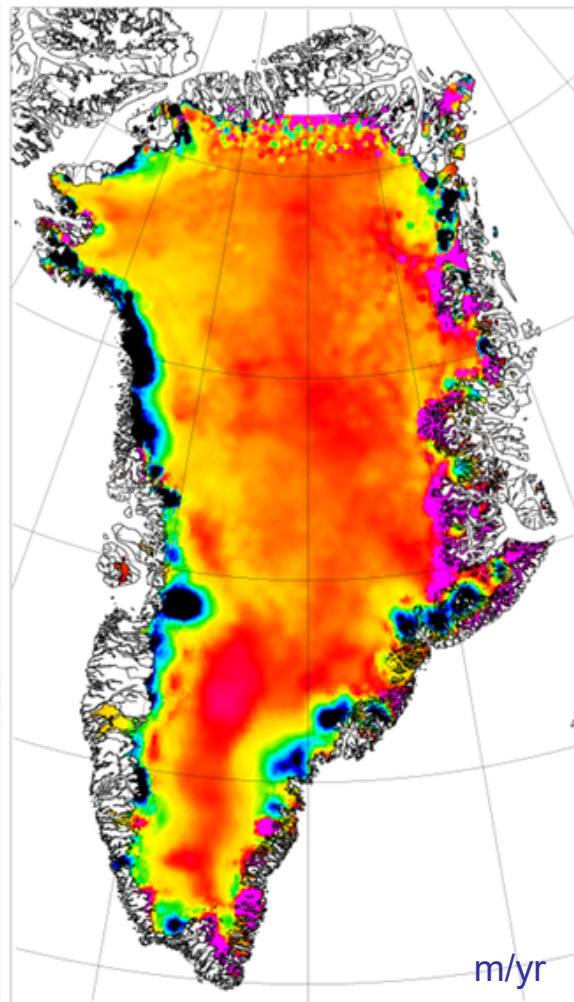
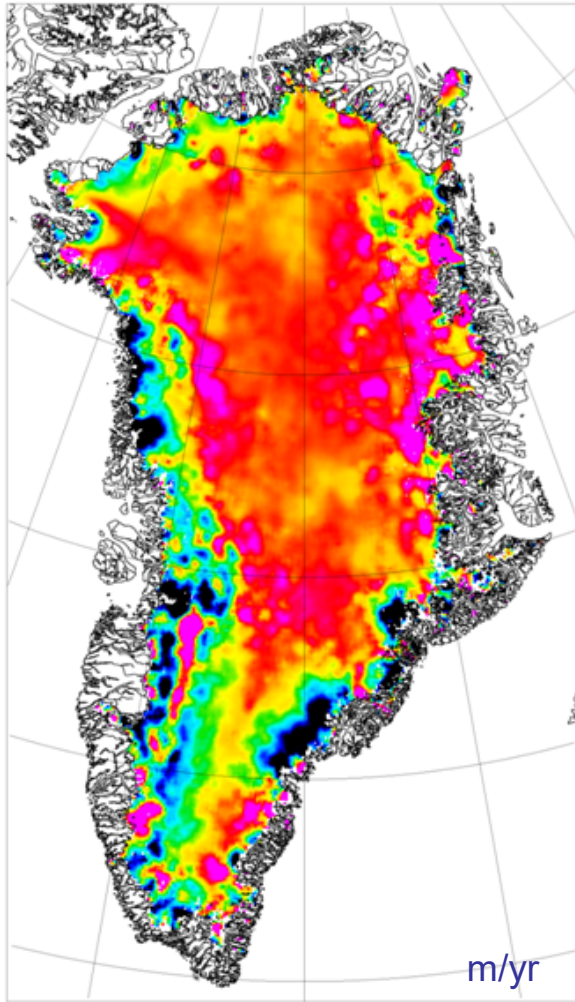

-0.8  0.2

-0.8  0.2

-800  200

M

GRACE, EnviSat, CryoSat data available from **ESA Climate Change Initiative project**

The ESA Greenland CCI project ... digested/gridded EO data at your fingertips ...

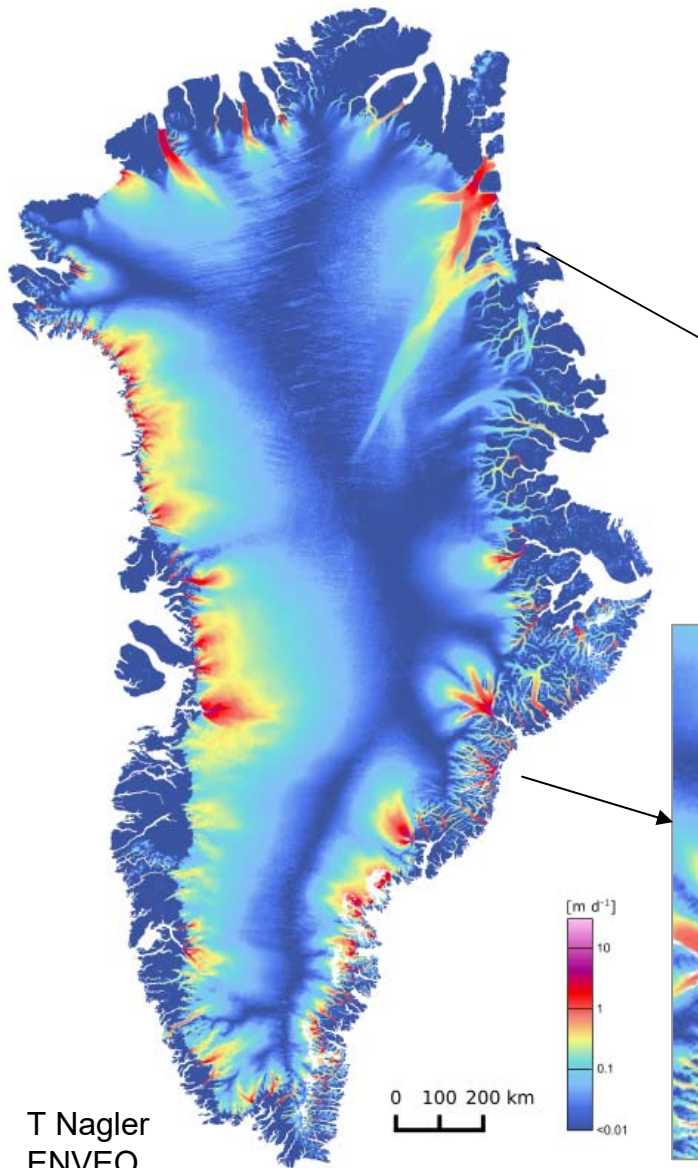

- **IV**: Ice velocity – greenland-wide and coast-near regions
- **SEC**: Surface elevation changes, ERS/Envisat/CryoSat, 1991-present
- **GLL**: Grounding lines from SAR, main northern floating glaciers 1991-present
- **CFL**: Calving front locations - 20+ main outlet glaciers 1991-present
- **GMB**: Gravimetric mass balance from GRACE

ECV grid/line data	SEC	IV	GLL	CFL	GMB
- Horizontal resolution	5 km	500 m	200 m	200 m	50 km
- Temporal resolution	1 yr	1 yr (12 days)	5 yr	1 yr	1 month
- Accuracy	0.1 m/yr	20 m/yr	1 km	200 m	20 GT

<http://www.esa-icesheets-greenland-cci.org>

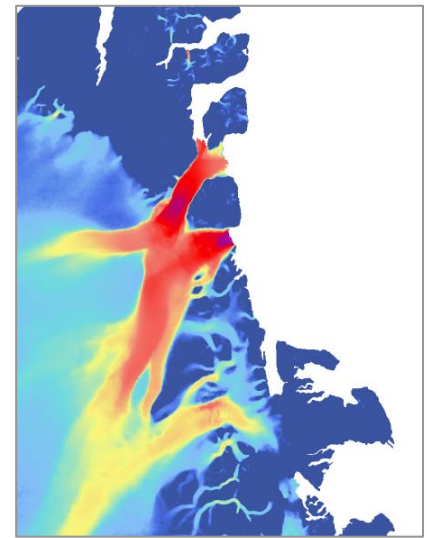
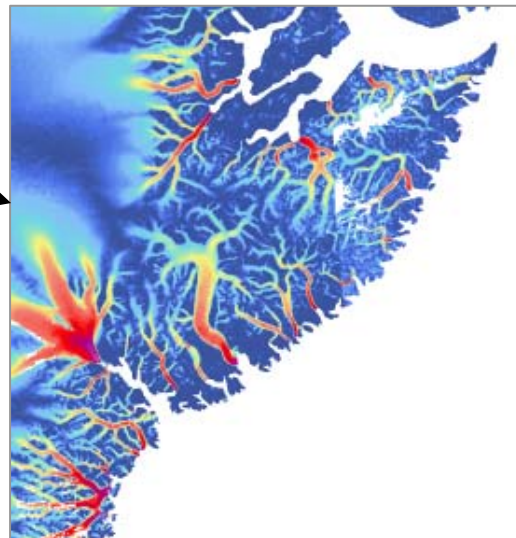

ERS-1, -2, EnviSat and CryoSat height changes 1992-2015

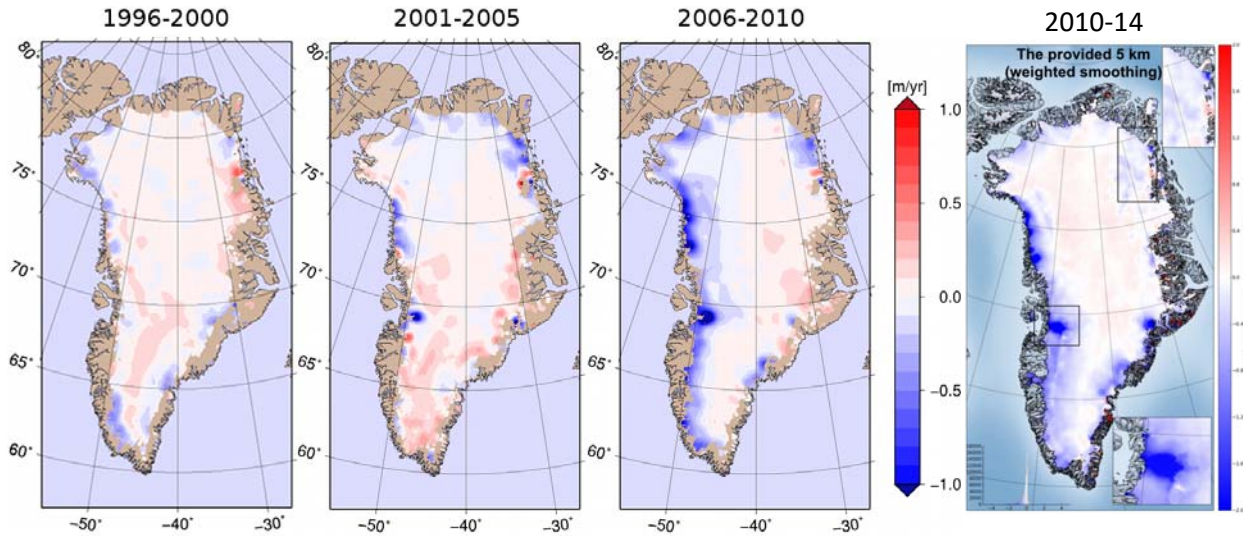

Calving front locations and grounding lines

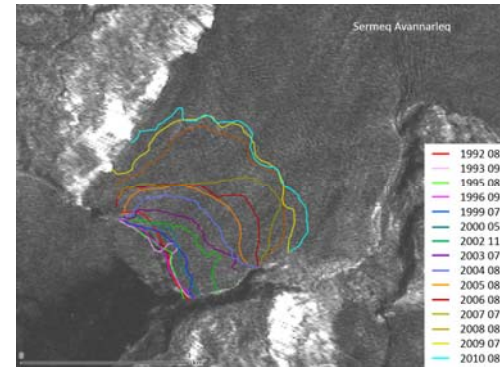

Ice velocity time series

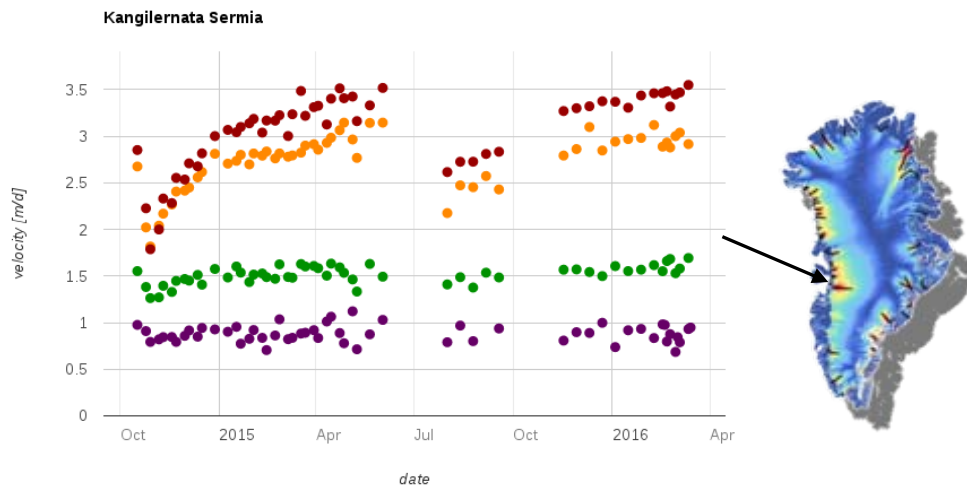

GRACE

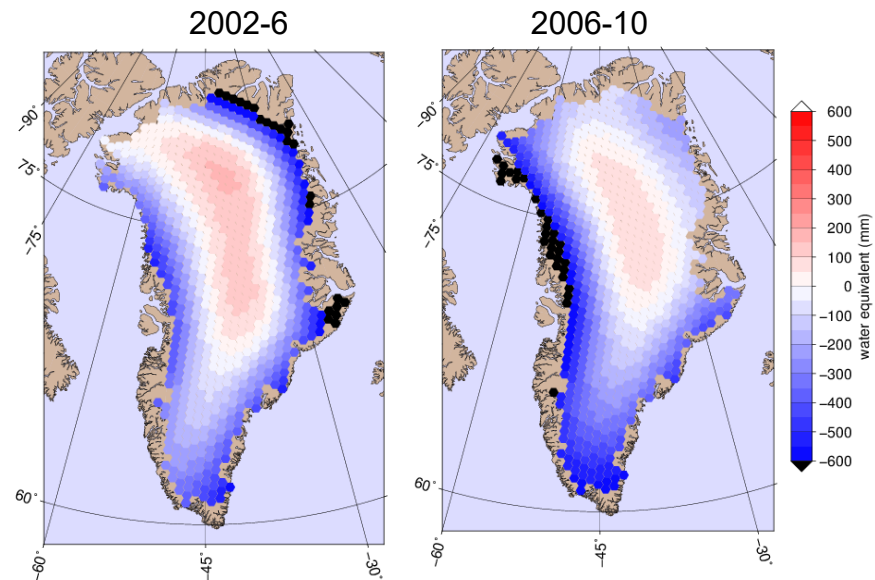

Demo: A simple software for GRACE analysis

- HARMEXP: spherical harmonic expansion (part of GRAVSOFIT package)
Make grids of gravity or geoid in spherical harmonics
- GRACEFIT: fitting trends and yearly terms to series of monthly GRACE grids
4-parameter fit: $dg(t) = a + b t + c \cos(\omega t) + d \sin(\omega t)$
- GRACEINV: making mass conversion by linear equation solution
Solve normal equations by Cholesky decomposition

These are Fortran programs. Use e.g. GNU-Fortran (open source) to compile. GRAVSOFIT grid formats easily plotted e.g. by GMT ("g2gmt") or Surfer ("g2sur")

*Run in GRAVSOFIT unix-like
Job setup*

*Elastic corrections, C_{20} etc handled
on coefficient level ahead of runs ..*

*GRAVSOFIT grid format: Data stored rowwise
from N to S, initiated with label:*

$\varphi_1, \varphi_2, \lambda_1, \lambda_2, \Delta\varphi, \Delta\lambda$

$d_{n1} \quad d_{n2} \quad \dots \quad d_{nm}$

.....

.....

$d_{11} \quad d_{12} \quad \dots \quad d_{1m}$

*Coordinates refer to center of cells.
Unknown data are signalled by "9999".
Grids may be in UTM or polar stereographic
projection (φ latitude/northing; λ longitude/easting)*

Thanks for your attention

